

RECOMMENDED PANEL MOUNTING

▲ SWITCH FUNCTION		
POS. 1	POS. 2	POS. 3
ON	NONE	ON
2-3, 5-6	N/A	2-1, 5-4

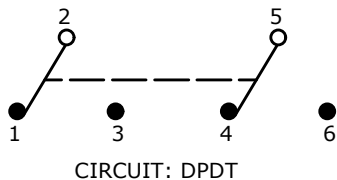

NOTE:

1. ALL DIMENSIONS IN MM [INCH]
2. GENERAL TOLERANCE: X.X = ±0.4
X.XX = ±0.25
3. TERMINAL NUMBERS FOR REF ONLY
- ▲ 4. CONTACT MATERIAL: SILVER
5. RATING: 2A @ 250 VAC
5A @ 120 VAC OR 28 VDC
6. ELECTRIC LIFE: 6,000 MAKE-AND-BREAK CYCLES AT FULL LOAD.
7. INSULATION RESISTANCE: 1,000 MEGA-OHM MIN.
8. DIELECTRIC STRENGTH: 1,000 V RMS @ SEA LEVEL
9. OPERATING TEMP.: -40°C TO 85°C
10. ▲ DENOTES CRITICAL PARAMETER.
11. HARDWARE INCLUDED
T100012 - LOCK WASHER - QTY 1
T100003 - LOCK RING - QTY 1
T100004 - HEX NUT - QTY 2

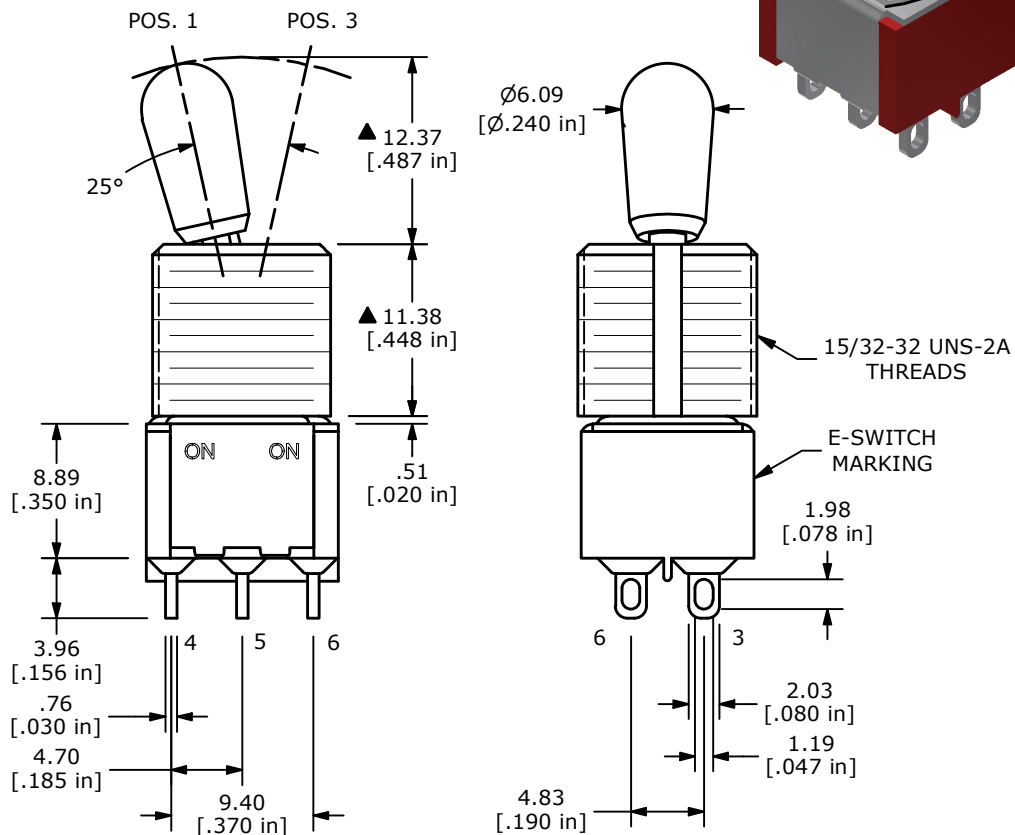
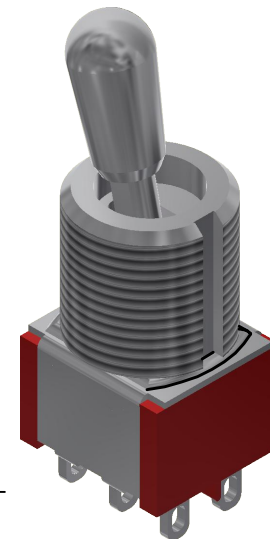
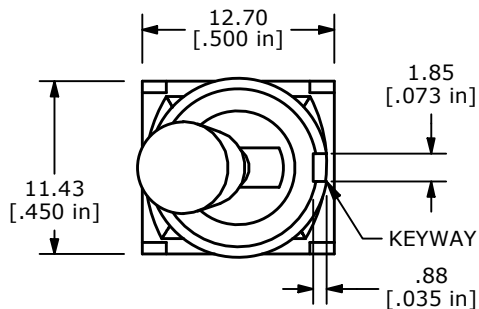

REV	ECO NO	DESCRIPTION	DATE	BY
B	ECO-102796	100 SERIES UPDATE	08/19/24	MR



OBJECT ID
000023141

TITLE 100DP1T7B13M1QEH				
SCALE 2:1	DATE 7/13/2007	DR MM	DWG ST121099	REV B