

SWITCH FUNCTION		
POS. 1	POS. 2	POS. 3
(ON)	OFF	(ON)
2-3	OPEN	2-1

(ON) = MOMENTARY

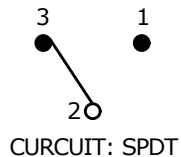

NOTES:

1. ALL DIMENSIONS IN MM [INCH]
2. TERMINAL NUMBERS FOR REF. ONLY
3. GENERAL TOLERANCE: X.X±0.4
X.XX±0.25
4. PLATING MATERIAL: GOLD
5. RATING: 0.4VA MAX. @ 20V (AC or DC)
6. CONTACT RESISTANCE: 20 MILLI-OHMS MAX.
7. MECHANICAL LIFE: 30,000 MAKE AND BREAK CYCLES AT FULL LOAD
8. INSULATION RESISTANCE: 1,000 MEGA-OHM MIN.
9. DIELECTRIC STRENGTH: 1,000 V RMS@SEA LEVEL
10. OPERATING TEMPERATURE: -30°C TO 85°C
11. PACKAGING: 500 PER REEL.
12. ▲DENOTES CRITICAL PARAMETER.
13. 2011/65/EU (ROHS) COMPLIANT

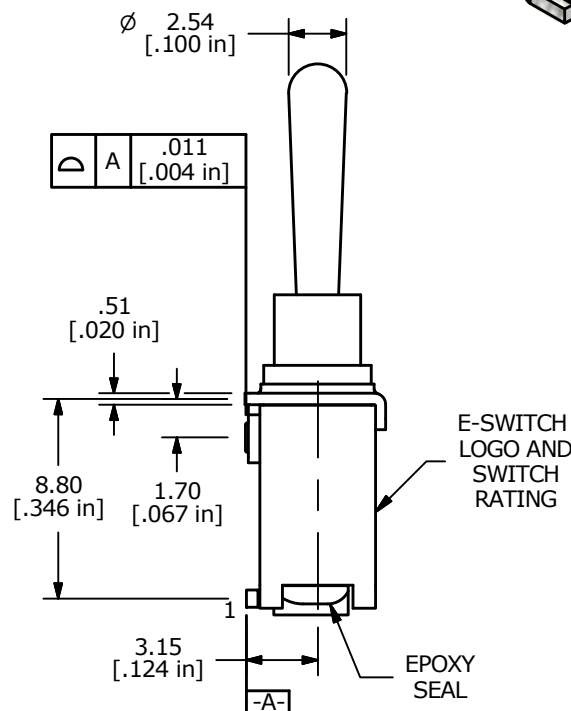
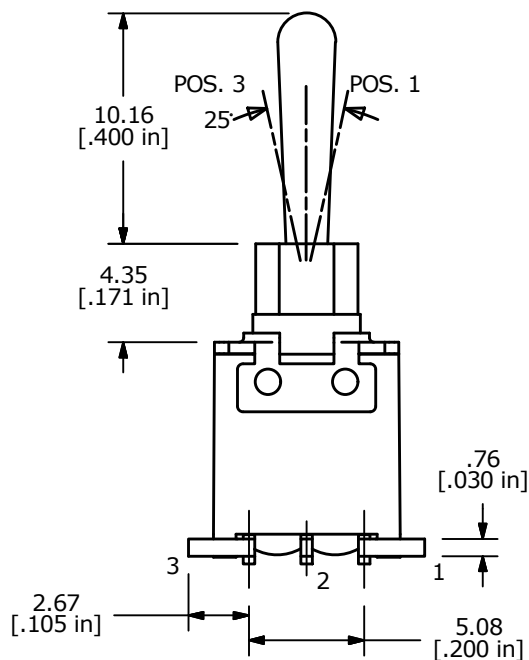

C	22358	UPDATED PAD LOCATIONS	6/17/16	MJR
B	n/a	TITLE CHANGE (WAS 200BWMSP3T1A1SM6RE)	4/16/09	BLR
REV	PCR NO	DESCRIPTION	DATE	BY

THE INFORMATION CONTAINED IN THIS DOCUMENT IS PROPRIETARY TO E-SWITCH AND IS NOT TO BE COPIED OR TRANSFERRED



TITLE 200BWMSP4T1A1SM6RE				
SCALE 3:1	DATE 4/16/2009	DR BLR	DWG T833044	REV C