

▲ SWITCH FUNCTION		
POS. 1	POS. 2	POS. 3
ON	NONE	(ON)
2-3, 5-6	N/A	2-1, 5-4

(ON)=MOMENTARY

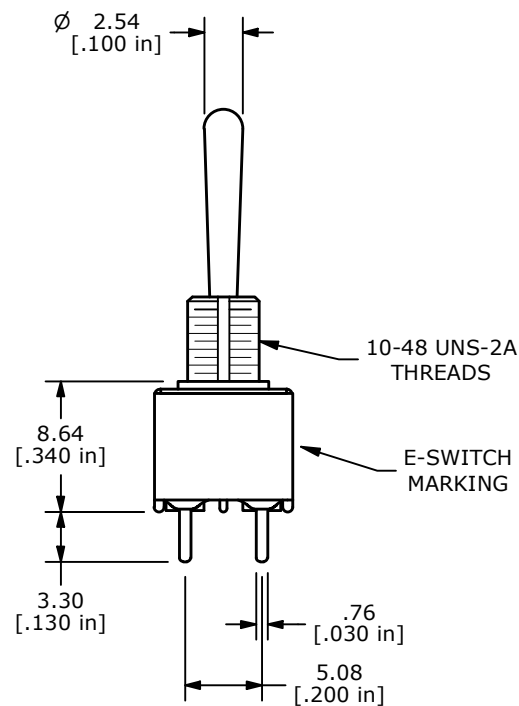
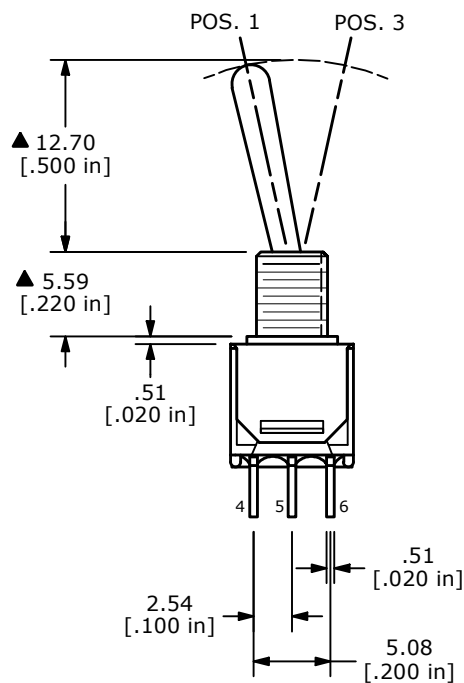
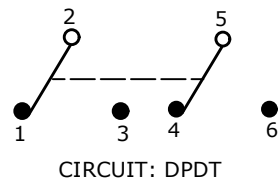

NOTE:

1. ALL DIMENSIONS IN MM [INCH]
2. GENERAL TOLERANCE: X.X = ±0.4
X.XX = ±0.25
3. TERMINAL NUMBERS FOR REF ONLY
- ▲ 4. PLATING MATERIAL: SILVER
5. RATING: 3AMPS @ 120VAC or 28VDC, 1AMP @ 250VAC
6. ELECTRICAL LIFE: 6,000 MAKE-AND-BREAK CYCLES AT FULL LOAD.
7. INSULATION RESISTANCE: 1,000 MEGA-OHM MIN.
8. DIELECTRIC STRENGTH: 1,000 V RMS @ SEA LEVEL
9. OPERATING TEMP.: -40°C to 85°C
10. ▲ DENOTES CRITICAL PARAMETER.
- ▲ 11. HARDWARE INCLUDED
T200001 - HEXNUT - QTY 2
T200000 - LOCKWASHER - QTY 1
T100002 - LOCKRING - QTY 1

REV	ECO NO	DESCRIPTION	DATE	BY
C	ECO-104005	Print update	03/20/26	MW



OBJECT ID
000023255

TITLE 200MDP2T4B3M2QE				
SCALE 2:1	DATE 3/18/2005	DR AR	DWG ST201218	REV C