

RECOMMENDED PANEL MOUNTING

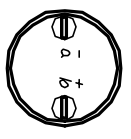
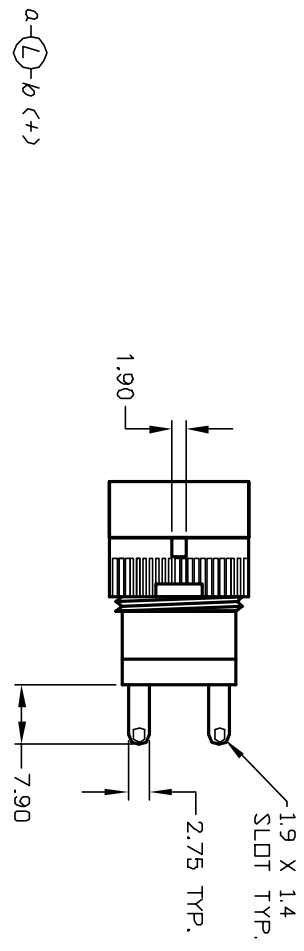

a-L-b (+)

CONTACT CONFIGURATION

NOTES:

1. ALL DIMENSIONS IN MM
2. GENERAL TOLERANCE: X.X=±0.4  
X.XX=±0.25
3. RATINGS: 250VAC @5A

REV.	ECN No.	REVISION	DATE	CHKD
C	11259	REVISED	2/21/01	CJB
THE INFORMATION CONTAINED IN THIS DOCUMENT IS PROPRIETARY TO E-SWITCH AND IS NOT TO BE COPIED OR TRANSMITTED				

TITLE		SCALE		DATE	DR	DWG	REV
L16 PL T1 00		1:1		2/21/01	CJB	F040001	C
<b>E-SWITCH®</b>							