

RECOMMENDED PANEL MOUNTING

PARTS LIST			
Item	Qty.	Dwg. No.	Part No.
1	1	F051701	29mm RING FOR LA SERIES
2	1	F060614	LASEEU110
3	1	F060294	29mm GREEN LENS
-	1	F050402	50-004-02 (LAMP)

1 0 0 2
 3 0 0 4
 a-(L)-b(+)

SPST
 CONTACT CONFIGURATION

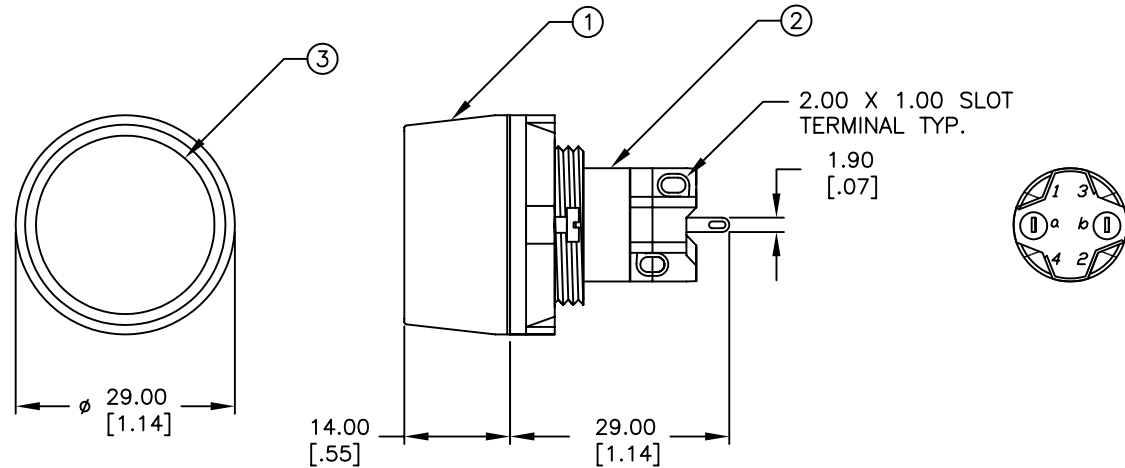

NOTES:

1. ALL DIMENSIONS IN MM [INCH]
2. GENERAL TOLERANCE: X.X=±0.4
 X.XX=±0.25
3. RATINGS: 250VAC @1A, 2A, 4A, 5A

E-SWITCH®

TITLE		LAS EE U1 1A GRN			
SCALE	DATE	DR	DWG	REV	
1:1	1/19/01	CJB	XF0303A	A	

A	11183	RELEASED FOR PRODUCTION	1/19/01	CJB
REV.	ECN No.	DESCRIPTION	DATE	CHKD

THE INFORMATION CONTAINED IN THIS DOCUMENT IS PROPRIETARY TO E-SWITCH AND IS NOT TO BE COPIED OR TRANSFERRED