

DETAIL-A- (SCALE 6:1)

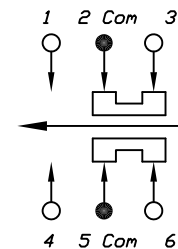

CIRCUIT: DPDT

CONTACT CONFIGURATION

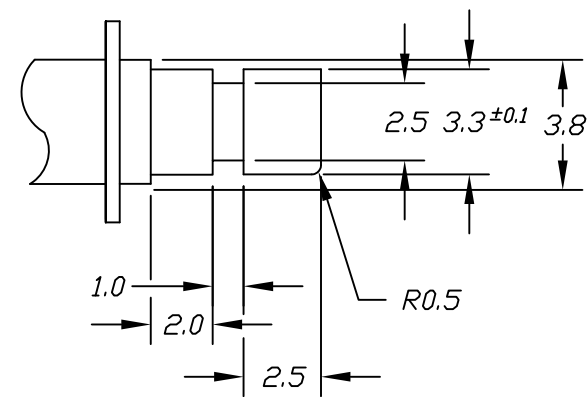
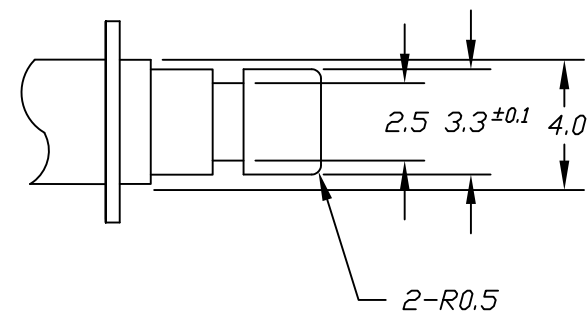
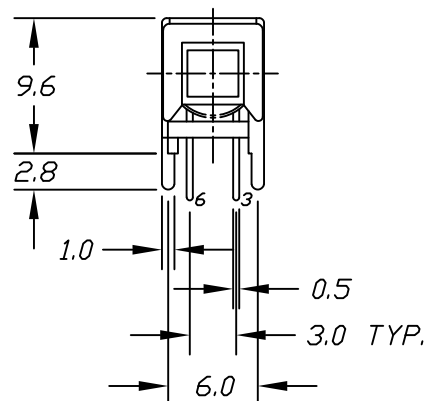
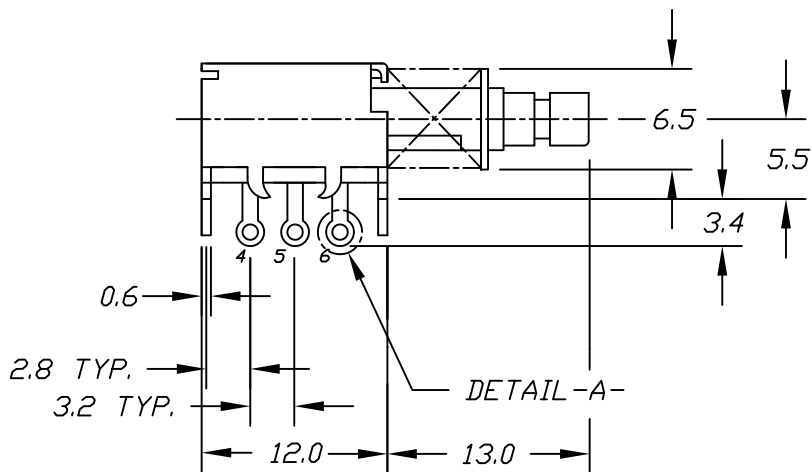

(ACTUATOR DETAIL) SCALE 4:1

NOTES:

1. ALL DIMENSIONS IN MM [IN]
2. TERM. NOS. FOR REF ONLY
3. RATING: DC 30V, 0.3A
4. OPERATING FORCE: 330±150gf
5. TRAVEL: FULL 3.5mm; LOCK 2.5mm

TOLERANCES	±0.4	±0.25
	0.0	0.00

**E-SWITCH®**

TITLE		LC 2255 EE N S			
SCALE	DATE	DR	DWG	REV	
2:1	5/9/97	MM	P070170	A	

THE INFORMATION CONTAINED IN THIS DOCUMENT IS PROPRIETARY TO E-SWITCH AND IS NOT TO BE COPIED OR TRANSFERRED

A	RELEASED FOR PRODUCTION		
REV.	DESCRIPTION	DATE	CHKD