

P.C. MOUNTING

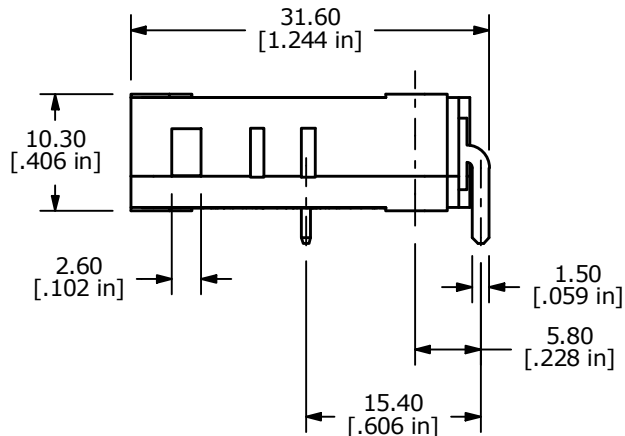

O.P. (MM)	P.T. (MM)
14.7±0.5	2.0 MAX.

O.P. = OPERATING POINT
P.T. = PRE-TRAVEL

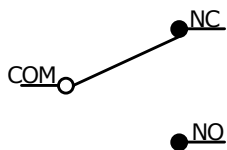

CIRCUIT: SPDT

NOTES:

1. ALL DIMENSIONS IN MM [INCH]
2. GENERAL TOLERANCE: X.X±0.4
X.XX±0.25
3. RATING: 15A @125/250VAC UL, CUL APPROVED
4. OPERATING FORCE: 100±30 GRAMS
5. OPERATING TEMP: -25°C TO 85°C
6. ELECTRICAL LIFE: 50,000 CYCLES MIN.
7. MECHANICAL LIFE: 1,000,000 CYCLES TYP.
8. INSULATION RESISTANCE: 100 MEGA-OHMS MIN.
9. DIELECTRIC STRENGTH: 1500VAC 1 MINUTE (INITIAL VALUE)
10. CONTACT RESISTANCE: 100 MILLI -OHMS MAX.
11. ▲ DENOTES CRITICAL PARAMETER.

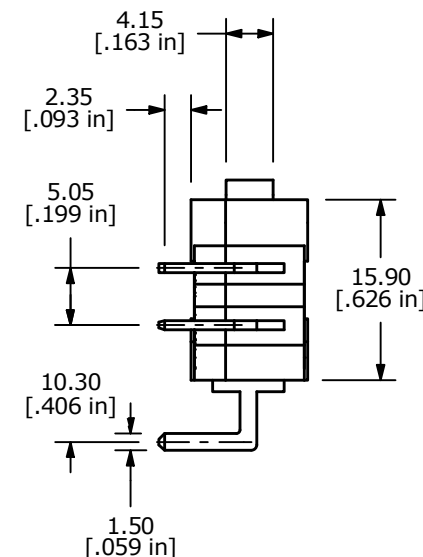
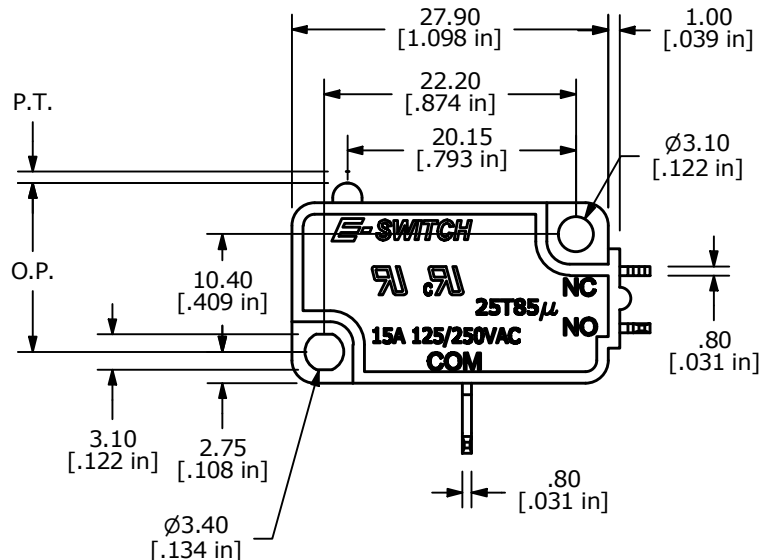

REV	ECO NO	DESCRIPTION	DATE	BY
C	ECO-100810	REMOVE VDE RATING AND LOGO	03/28/22	JS



OBJECT ID
000020997

TITLE LS0851500F100V2A		SCALE 3:2	DATE 8/30/2005	DR PH	DWG Q950009	REV C
---------------------------	--	--------------	-------------------	----------	----------------	----------