

P.C. MOUNTING

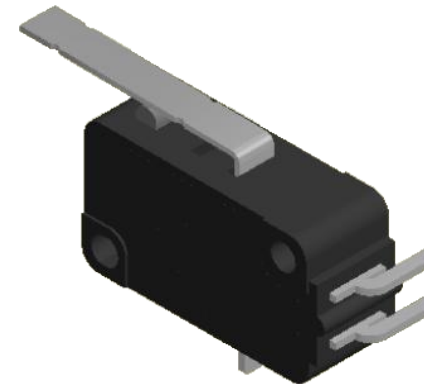

O.P. (MM)	P.T. (MM)
15.5±0.8	4.1 MAX.

O.P. = OPERATING POINT  
P.T. = PRE-TRAVEL

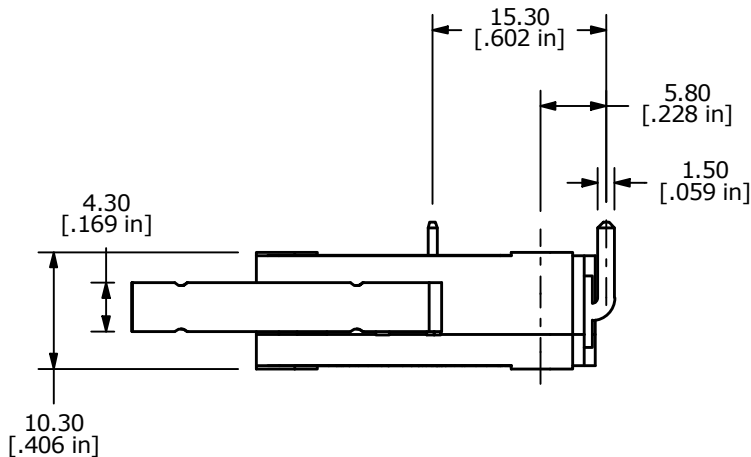
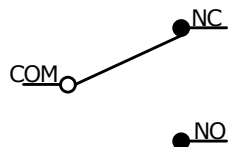

CIRCUIT: SPDT

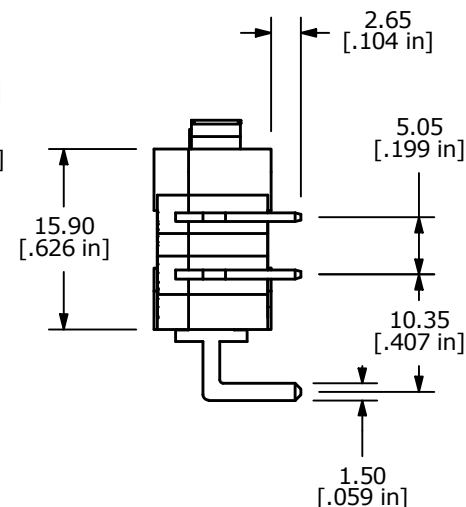
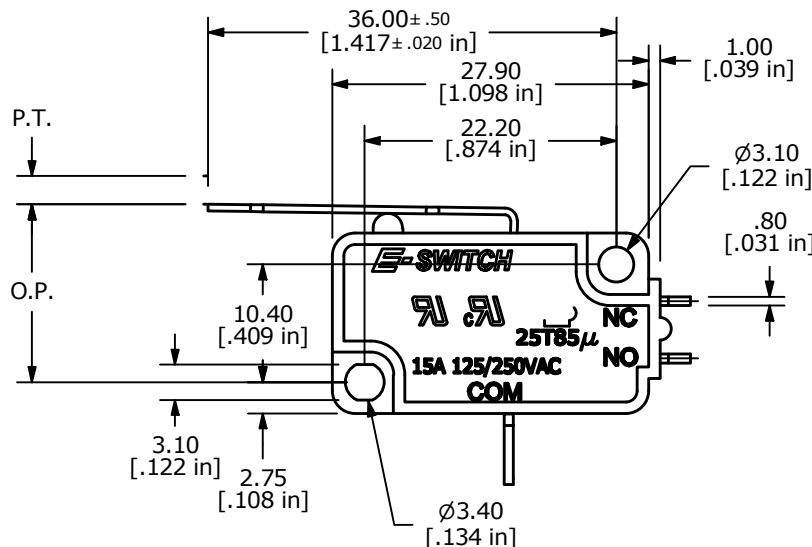

NOTES:

1. ALL DIMENSIONS IN MM [INCH]
2. GENERAL TOLERANCE: X.X±0.4  
X.XX±0.25
3. RATING: 15A @125/250VAC UL, CUL APPROVED
4. OPERATING FORCE: 120± 40 GRAMS
5. OPERATING TEMP: -25°C TO 85°C
6. ELECTRICAL LIFE: 50,000 CYCLES MIN.
7. MECHANICAL LIFE: 1,000,000 CYCLES TYP.
8. INSULATION RESISTANCE: 100 MEGA-OHMS MIN.
9. DIELECTRIC STRENGTH: 1500VAC 1 MINUTE (INITIAL VALUE)
10. CONTACT RESISTANCE: 100 MILLI -OHMS MAX.
11. ▲ DENOTES CRITICAL PARAMETER.

REV	ECO NO	DESCRIPTION	DATE	BY
C	ECO-100827	REMOVE VDE RATING AND LOGO	04/11/22	JS



OBJECT ID  
000021022

TITLE LS0851502F120V1A		SCALE 3:2	DATE 7/7/2006	DR BK	DWG Q950035	REV C
---------------------------	--	--------------	------------------	----------	----------------	----------