

CIRCUIT: DPDT

NOTE:

1. ALL DIMENSIONS IN MM [INCH]
2. GENERAL TOLERANCE: X.X=±0.4
X.XX=±0.25
3. TERMINAL NUMBERS FOR REF ONLY
- ▲4. RATING: 5A @ 250VAC; 8A @ 125VAC
5. INSULATION RESISTANCE: 50 MEGA-OHMS (INITIAL)
- ▲6. ELECTRICAL LIFE: 6000 CYCLES
7. CONTACT MATERIAL: SILVER
8. OPERATING TEMP.: -25°C to 55°C
9. STORAGE TEMP.: -40°C to 70°C
10. ▲ DENOTES CRITICAL PARAMETER.
11. 2002/95/EC (ROHS) COMPLIANT
12. PACKAGING: SHIPPED SEPARATELY IN BULK
13. LAMP: LED 12VDC
14. INGRESS PROTECTION: IP65

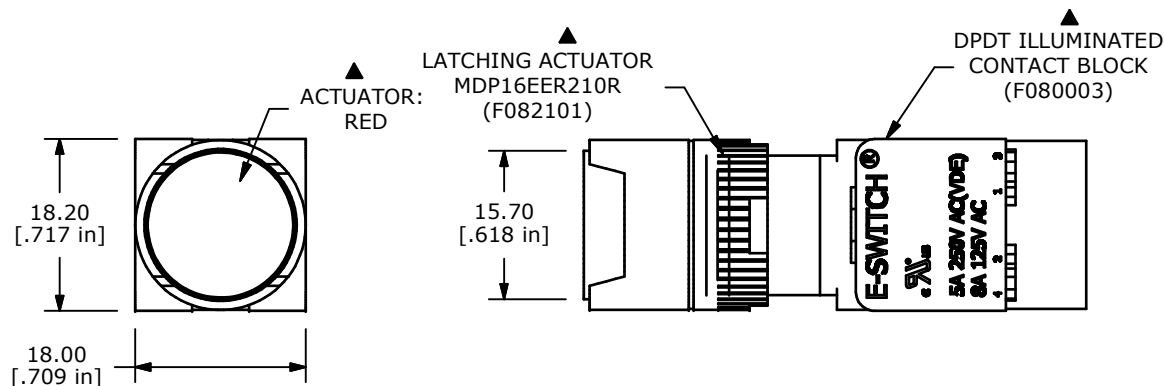

A	21439	RELEASED FOR PRODUCTION	4/21/14	EBP
REV	PCR NO	DESCRIPTION	DATE	BY

TITLE MDP16EER2210R				
SCALE	DATE	DR	DWG	REV
	4/21/2014	EBP	XF0892P	A

THE INFORMATION CONTAINED IN THIS DOCUMENT IS PROPRIETARY TO E-SWITCH AND IS NOT TO BE COPIED OR TRANSFERRED