

PANEL THICKNESS	X
0.75-1.25	19.2
1.25-2.00	19.4
2.00-3.00	19.8

RECOMMENDED PANEL CUT-OUT

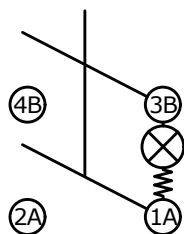

▲ OFF-ON DPST

SCHEMATIC

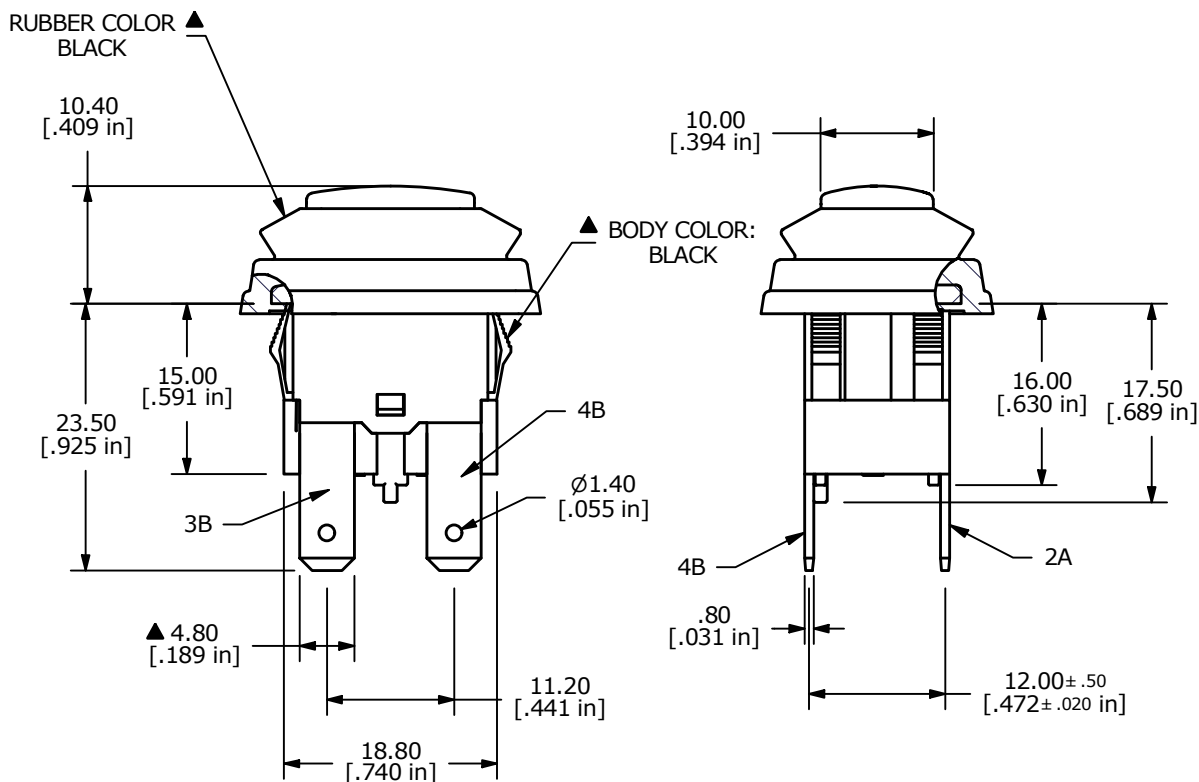
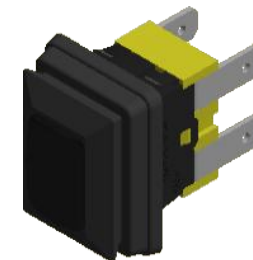
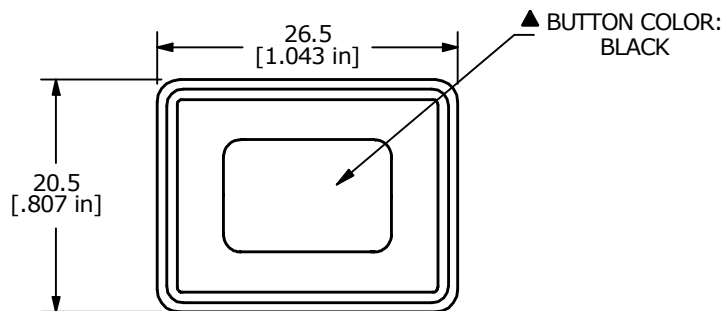

NOTES:

1. ALL DIMENSIONS IN MM [INCH]
2. GENERAL TOLERANCE: X.X=± 0.4
X.XX=± 0.25
3. ELECTRICAL LIFE: 6,000 [cURus]
4. CONTACT RESISTANCE: 20 mΩ MAX. INITIAL
5. INSULATION RESISTANCE: 100 MΩ AT 500VDC
6. OPERATING TEMPERATURE: -20°C TO +65°C [cURus]
7. CONTACT RATING: 16A, 125VAC-250VAC, [cURus]
8. DIELECTRIC STRENGTH: 1000V FOR 1 MINUTE
9. ▲ DENOTES CRITICAL PARAMETER

REV	ECO NO	DESCRIPTION	DATE	BY
C	ECO-100492	REMOVE VDE FROM NOTES	12/14/21	JS



OBJECT ID
000000239

TITLE PA4R12C1100		SCALE 2:1	DATE 8/15/2014	DR RC	DWG 14-PA4R12C1100	REV C
----------------------	--	--------------	-------------------	----------	-----------------------	----------