

RECOMMENDED PANEL MOUNTING

PANEL THICKNESS	X
0.75-1.25	19.2
1.25-2.00	19.4
2.00-3.00	19.6

SWITCH FUNCTION	
POS. 1	POS. 2
OFF	ON
OFF	1-2

▲ HOUSING  
COLOR: BLACK

▲ ACTUATOR  
ILLUMINATION  
COLOR: GREEN

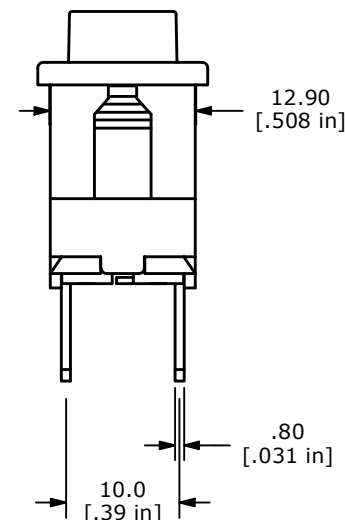
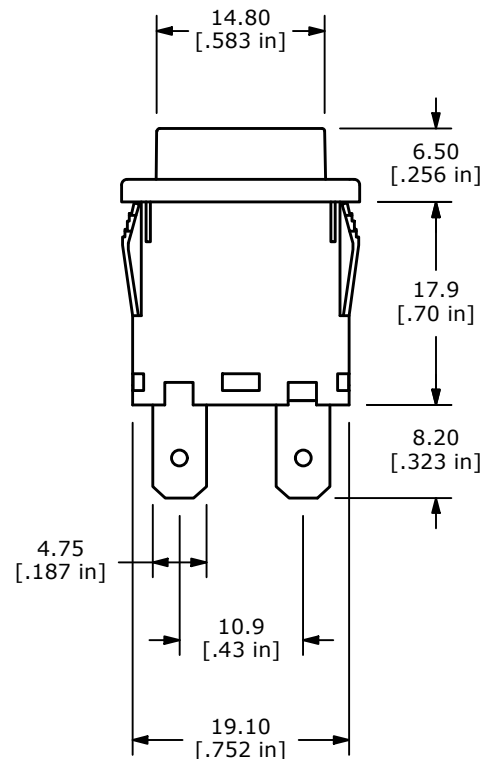
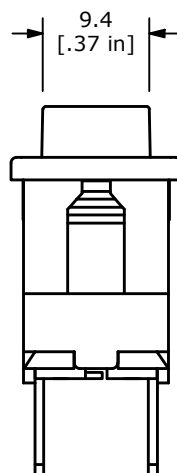
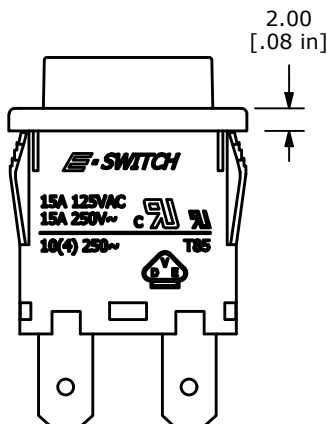
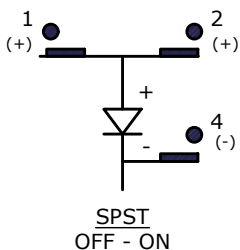
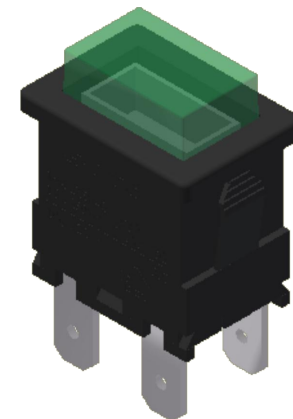
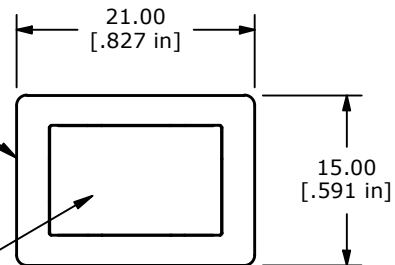

NOTES:

- ALL DIMENSIONS IN MM [INCH]
- GENERAL TOLERANCE: X.X=± 0.4  
X.XX=± 0.25
- MECHANICAL LIFE: 30,000
- ELECTRICAL LIFE: 10,000
- CONTACT RESISTANCE: 20 mΩ
- INSULATION RESISTANCE: 1000 MΩ
- OPERATING TEMPERATURE: -10°C TO 55°C
- CONTACT RATING: 15A-250 VAC, 125VAC UL APPROVED  
10A 250VAC, VDE APPROVED
- DIELECTRIC STRENGTH: 1500V FOR 1 MIN
- LAMP: LED, 12VDC
- ▲ DENOTES CRITICAL PARAMETER
- OPERATING FORCE: 750±100grams

REV	ECO NO	DESCRIPTION	DATE	BY
E	ECO-103805	LAMP TO LED	12/15/25	JS



OBJECT ID  
000016527

TITLE PB1973CBLKGILEF3				
SCALE	DATE	DR	DWG	REV
3:2	9/27/2007	BF	M197305	E