

PANEL CUTOUT
MAX. PANEL THICKNESS 11mm

SWITCH FUNCTION	
POS. 1	POS. 2
ON	(ON)
1-3, 4-6	1-2, 4-5

(ON) = MOMENTARY

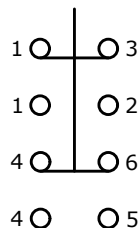

▲ DPDT ON-(ON)
CONTACT CONFIGURATION

- NOTE:
- ALL DIMENSIONS IN MM [INCH]
 - GENERAL TOLERANCE: X.X = ±0.4
X.XX = ±0.25
 - TERMINAL NUMBERS FOR REF ONLY
 - CONTACT MATERIAL: SILVER
 - RATING: 2A 48VDC
 - ELECTRIC LIFE: 50,000 MAKE-AND-BREAK CYCLES AT FULL LOAD.
 - INSULATION RESISTANCE: 1,000 MΩ MIN.
 - DIELECTRIC STRENGTH: 2,000 VAC MIN. FOR 1 MINUTE
 - CONTACT RESISTANCE: 50mΩ MAX. @ 1A 12VDC
 - OPERATING TEMP.: -20°C to 55°C
 - ▲ DENOTES CRITICAL PARAMETER.
 - HARDWARE SUPPLIED: O-RING AND HEXNUT
 - INGRESS RATING: IP40
 - LAMP VOLTAGE: NO LAMP

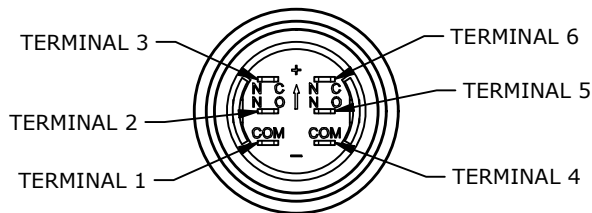
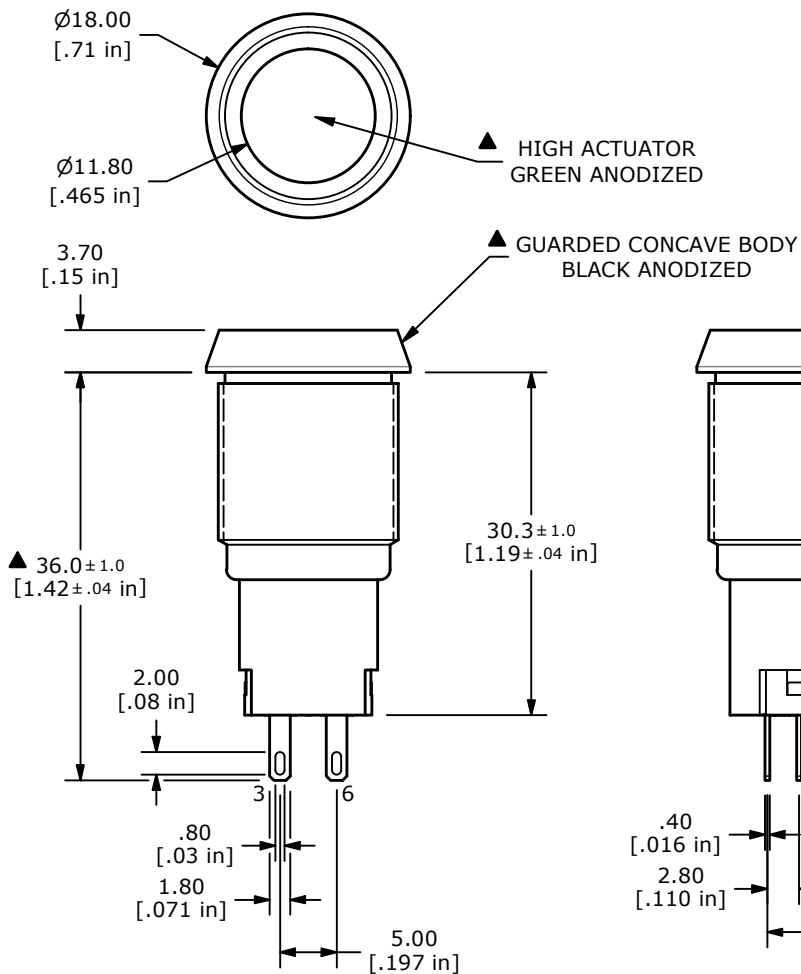

REV	ECO NO	DESCRIPTION	DATE	BY
A	ECO-102044	Release	06/30/23	MW



OBJECT ID
100125000

TITLE PV3WG2H018				
SCALE 3:2	DATE 6/20/2023	DR MW	DWG 52-PV3WG2H018	REV A