

RECOMMENDED PANEL CUTOUT
MAX. PANEL THICKNESS
11.0 [.43 in]

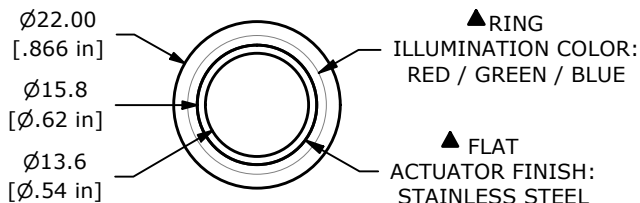

SWITCH FUNCTION	
POS. 1	POS. 2
ON	ON
1-3	1-2

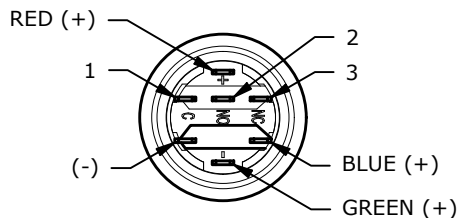
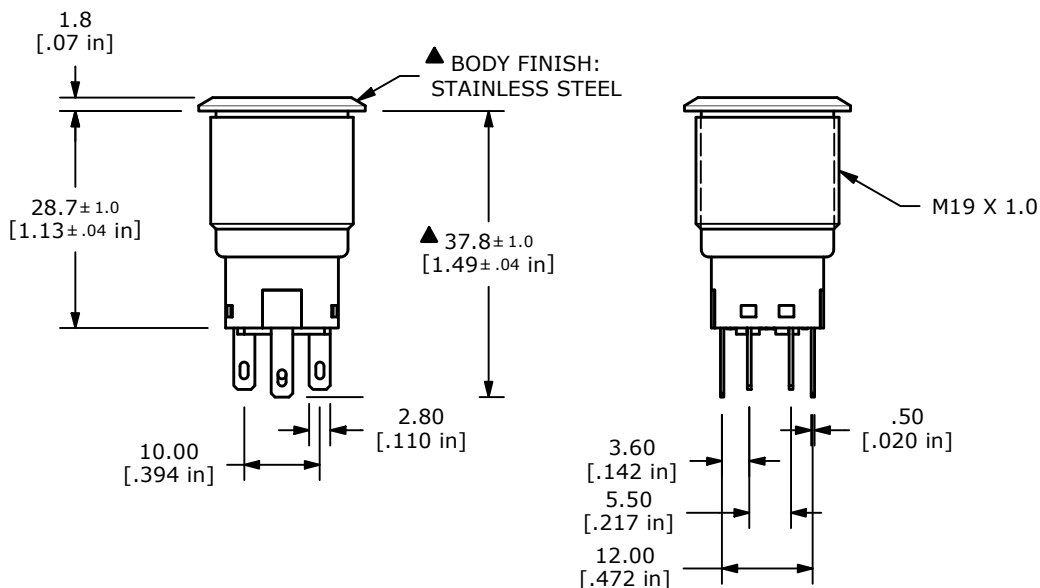
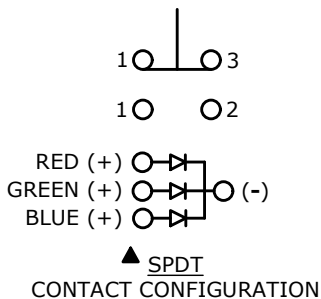

- NOTE:
- ALL DIMENSIONS IN MM [INCH]
 - GENERAL TOLERANCE: X.X = ±0.4
X.XX = ±0.25
 - TERMINAL NUMBERS FOR REF ONLY
 - CONTACT MATERIAL: SILVER
 - RATING: 2A 24VDC
 - ELECTRIC LIFE: 50,000 MAKE-AND-BREAK CYCLES AT FULL LOAD.
 - INSULATION RESISTANCE: 1,000 MΩ MIN.
 - DIELECTRIC STRENGTH: 2,000 VAC MIN. FOR 1 MINUTE
 - CONTACT RESISTANCE: 50mΩ MAX. @ 1A 12VDC
 - OPERATING TEMP.: -40°C TO 85°C
 - TRAVEL: 2.8 [.11 in]
 - ▲ DENOTES CRITICAL PARAMETER
 - INGRESS PROTECTION: IP67
 - HARDWARE SUPPLIED: O-RING AND HEXNUT
 - ILLUMINATION VOLTAGE: 12V

REV	ECO NO	DESCRIPTION	DATE	BY	E-SWITCH®				OBJECT ID
B	ECO-103809	PV4 SERIES UPDATE	01/07/26	MR					000002577
					TITLE PV4F230SS-3R4				
					SCALE 1:1	DATE 8/18/2016	DR MW	DWG 52-PV4F230SS3R4	REV B