

RECOMMENDED PANEL CUTOUT
MAX. PANEL THICKNESS 10mm

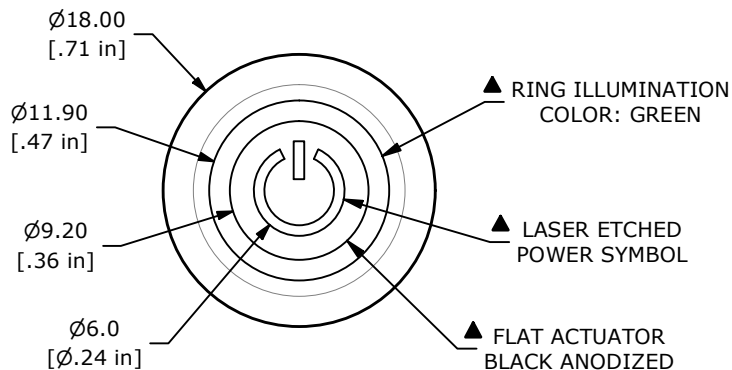

SWITCH FUNCTION	
POS. 1	POS. 2
OFF	(ON)
OPEN	1-2

(ON) = MOMENTARY

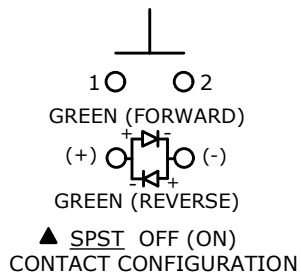

- NOTE:
- ALL DIMENSIONS IN MM [INCH]
 - GENERAL TOLERANCE: X.X = ±0.4
X.XX = ±0.25
 - TERMINAL NUMBERS FOR REF ONLY
 - CONTACT MATERIAL: SILVER
 - RATING: 2A 48VDC
 - ELECTRICAL LIFE: 50,000 MAKE-AND-BREAK CYCLES AT FULL LOAD.
 - INSULATION RESISTANCE: 1,000 MΩ MIN.
 - DIELECTRIC STRENGTH: 2,000 VAC MIN. FOR 1 MINUTE
 - CONTACT RESISTANCE: 50mΩ MAX. @ 1A 12VDC
 - OPERATING TEMP.: -40°C to 85°C
 - TRAVEL: 1.8mm
 - ▲ DENOTES CRITICAL PARAMETER.
 - ILLUMINATION VOLTAGE: 2.8V 20mA
 - ILLUMINATION COLOR: GREEN
 - HARDWARE SUPPLIED: O-RING AND HEXNUT (NOT SHOWN)

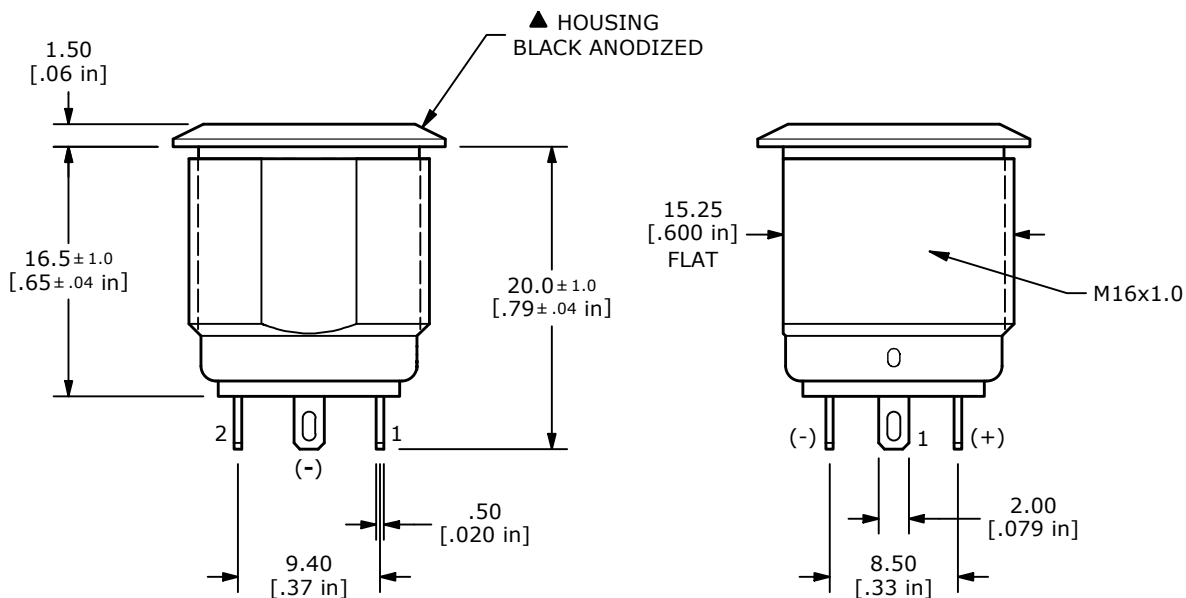

REV	ECO NO	DESCRIPTION	DATE	BY	E-SWITCH®				OBJECT ID
A	ECO-103084	Release	11/18/24	MW					100128797
					TITLE PV6F24011-331-M01				
					SCALE	DATE	DR	DWG	REV
					2:1	11/8/2024	MW	52-PV6F24011331M01	A

THE INFORMATION CONTAINED IN THIS DOCUMENT IS PROPRIETARY TO E-SWITCH AND IS NOT TO BE COPIED OR TRANSFERRED