

RECOMMENDED PANEL CUTOUT
MAX. PANEL THICKNESS 10mm

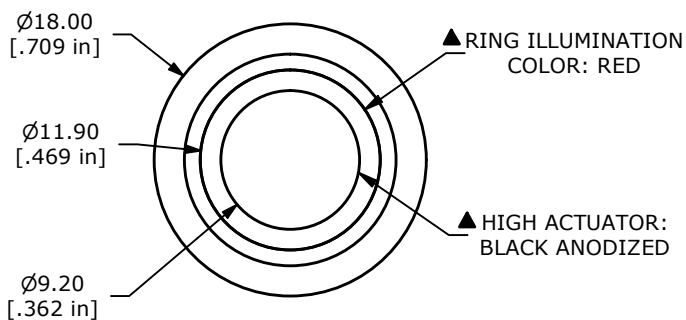

SWITCH FUNCTION	
POS. 1	POS. 2
OFF	(ON)
OPEN	1-2

(ON) = MOMENTARY

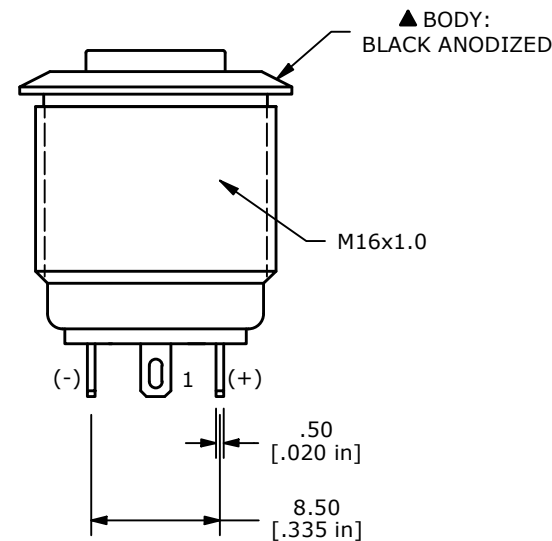
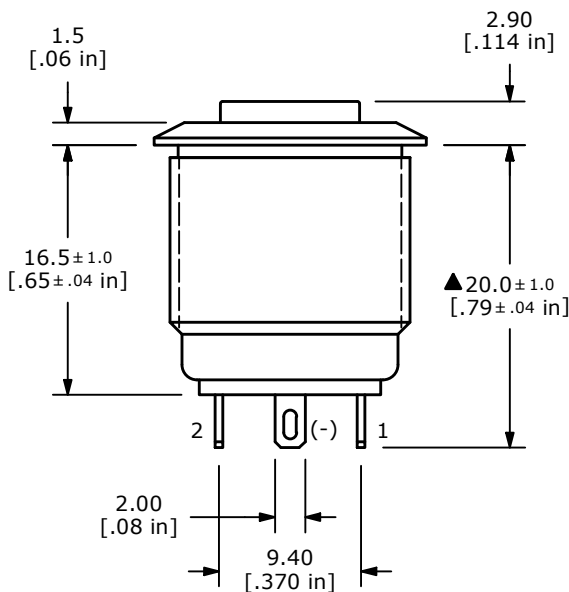
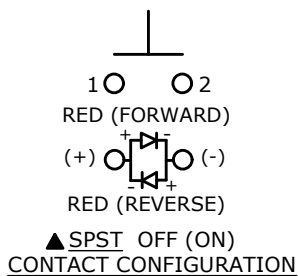

- NOTE:
- ALL DIMENSIONS IN MM [INCH]
 - GENERAL TOLERANCE: X.X±0.4
X.XX±0.25
 - TERMINAL NUMBERS FOR REF ONLY
 - CONTACT MATERIAL: SILVER PLATED
 - RATING: 2A 48VDC
 - ELECTRIC LIFE: 50,000 MAKE-AND-BREAK CYCLES AT FULL LOAD.
 - INSULATION RESISTANCE: 1,000 MΩ MIN.
 - DIELECTRIC STRENGTH: 2,000 VAC MIN. FOR 1 MINUTE
 - CONTACT RESISTANCE: 50mΩ MAX. @ 1A 12VDC
 - OPERATING TEMP.: -40°C to 85°C
 - TRAVEL: 1.8mm
 - ▲ DENOTES CRITICAL PARAMETER.
 - ▲ ILLUMINATION VOLTAGE: 1.8V
 - INGRESS PROTECTION: IP65
 - HARDWARE SUPPLIED: O-RING AND HEXNUT (NOT SHOWN)

REV	ECO NO	DESCRIPTION	DATE	BY
B	ECO-103485	PRINT UPDATE	07/03/25	JS



OBJECT ID
000002905

TITLE PV6H24011-311		SCALE 2:1	DATE 11/17/2014	DR rc	DWG 52-PV6H24011311	REV B
------------------------	--	--------------	--------------------	----------	------------------------	----------