

SWITCH FUNCTION	
POS. 1	POS. 2
ON	ON
C - NC	C - NO

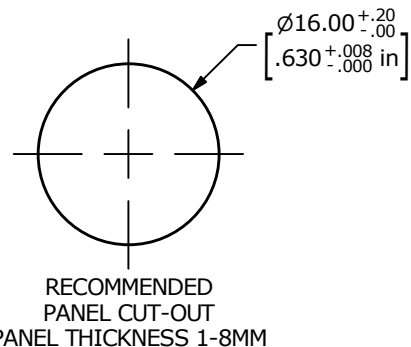

NOTE:

- ALL DIMENSIONS IN mm [INCH]
- GENERAL TOLERANCE: X.X = ±0.4  
X.XX = ±0.25
- TERMINAL NUMBERS FOR REF ONLY
- CONTACT MATERIAL: SILVER
- RATING: 2A 36VDC
- ELECTRIC LIFE: 50,000 MAKE-AND-BREAK CYCLES AT FULL LOAD.
- INSULATION RESISTANCE: 1,000 MΩ MIN.
- DIELECTRIC STRENGTH: 1,500 VAC MIN. FOR 1 MINUTE
- CONTACT RESISTANCE: 50mΩ MAX.
- OPERATING TEMP.: -25°C to 55°C
- TRAVEL: 3.0mm
- ▲ DENOTES CRITICAL PARAMETER
- ACTUATION FORCE: 1.7N NOMINAL
- INGRESS PROTECTION: IP65
- HARDWARE SUPPLIED: O-RING AND HEXNUT
- ▲ LAMP VOLTAGE: BASE VOLTAGE  
1.8V RED; 2.8V GREEN; 2.8V BLUE

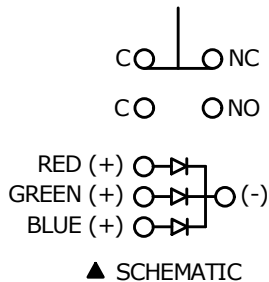
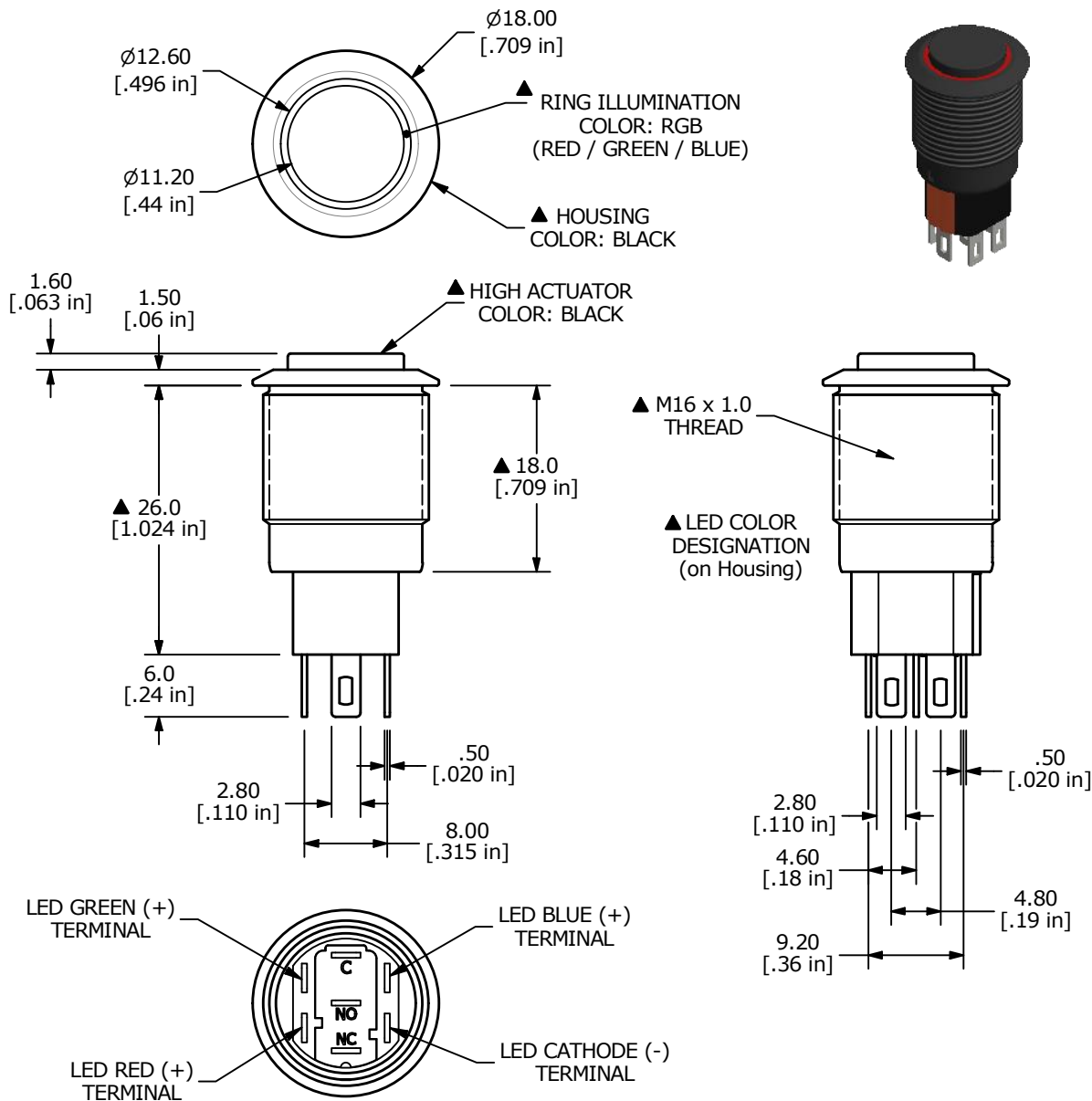

REV	ECO NO	DESCRIPTION	DATE	BY
E	ECO-101599	PRINT UPDATE	02/01/23	JS

				OBJECT ID 000003243
TITLE PVA3H230113R1				

SCALE 3:2	DATE 3/1/2018	DR MJR	DWG 52-PVA3H230113R1	REV E
--------------	------------------	-----------	-------------------------	----------