

RECOMMENDED PANEL CUTOUT  
MAX. PANEL THICKNESS 7.0 [.275 in]

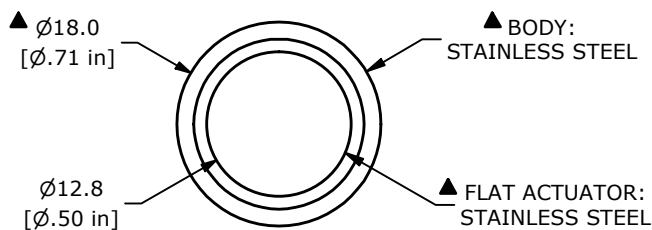

SWITCH FUNCTION	
POS. 1	POS. 2
ON	ON
1-3	1-2

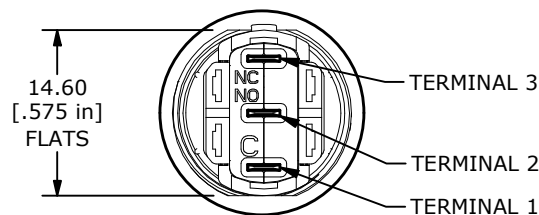
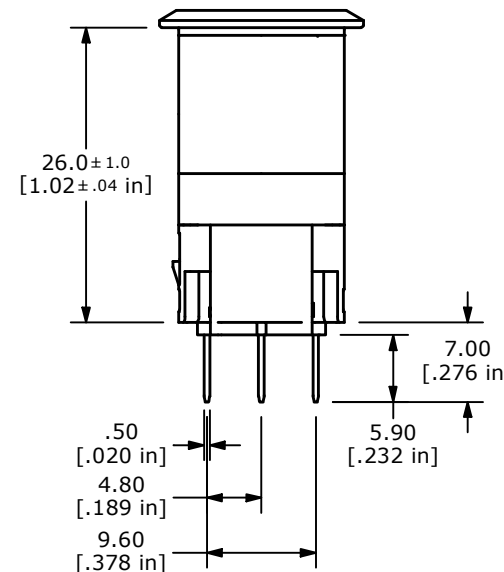
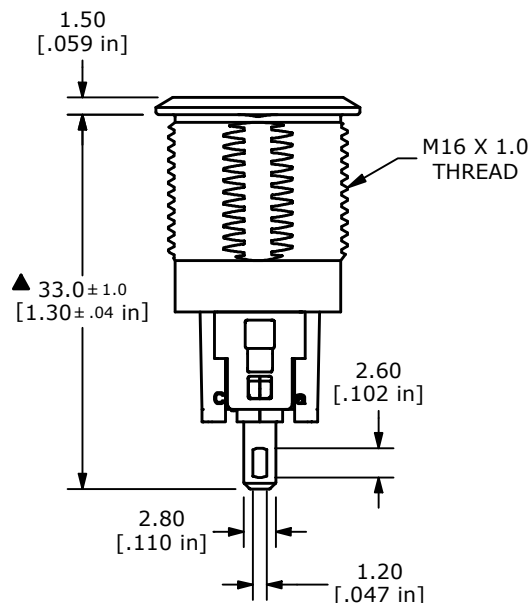
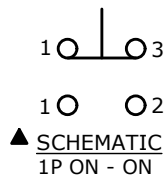

- NOTE:
- ALL DIMENSIONS IN MM [INCH]
  - GENERAL TOLERANCE: X.X = ±0.4  
X.XX = ±0.25
  - TERMINAL NUMBERS FOR REF ONLY
  - CONTACT MATERIAL: SILVER
  - RATING: 2A, 24VDC / 1.5A, 250VAC
  - ELECTRIC LIFE: 50,000 MAKE-AND-BREAK CYCLES AT FULL LOAD.
  - INSULATION RESISTANCE: 100 MΩ MIN.
  - DIELECTRIC STRENGTH: 1,500 VAC MIN. FOR 1 MINUTE
  - CONTACT RESISTANCE: 50mΩ MAX.
  - ▲ OPERATING TEMP.: -40°C to +85°C (NO FREEZING, KEEP THE AIR FLOWING AROUND THE PUSHBUTTON).
  - ▲ ▲ DENOTES CRITICAL PARAMETER.
  - HARDWARE SUPPLIED: O-RING AND HEXNUT
  - ▲ INGRESS RATING: IP67
  - LAMP VOLTAGE: N/A

REV	ECO NO	DESCRIPTION	DATE	BY
A	ECO-103231	RELEASE	02/13/25	JS



OBJECT ID  
100129700

TITLE PVB3F230SS		SCALE 3:2	DATE 2/12/2025	DR JS	DWG 52-PVB3F230SS	REV A
---------------------	--	--------------	-------------------	----------	----------------------	----------