

RECOMMENDED PANEL MOUNTING

PANEL THICKNESS	X
0.70-1.25	19.2-19.3
1.25-2.00	19.3-19.4
2.00-3.00	19.5-19.6

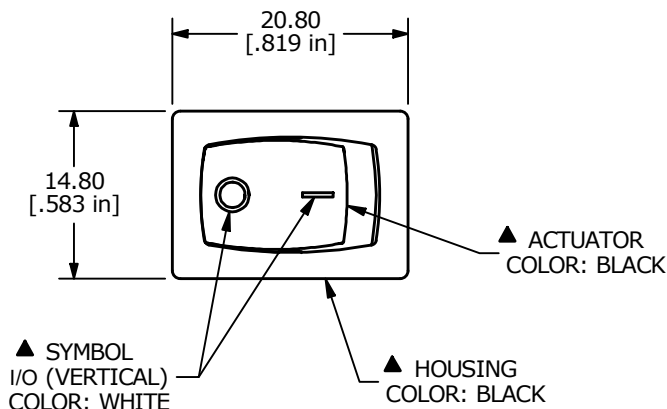

▲ SWITCH FUNCTION		
POS. 1	POS. 2	POS. 3
OFF	NONE	ON
OPEN	N/A	1-1a

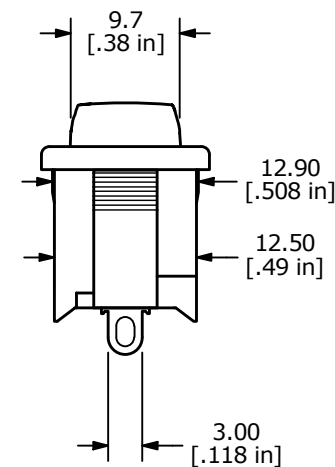
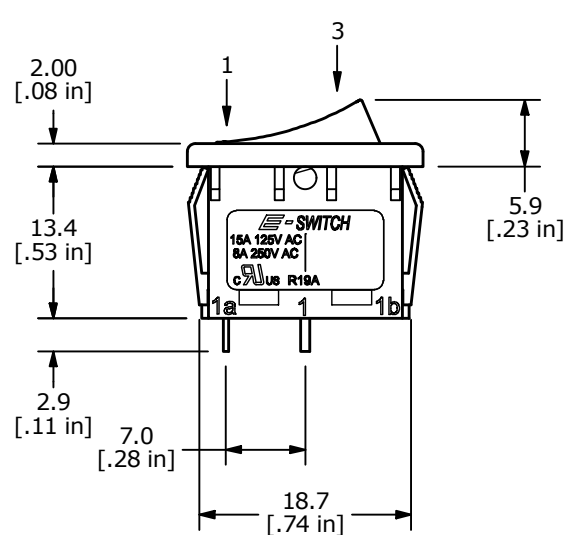
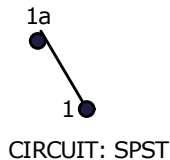

NOTES:

- ALL DIMENSIONS IN MM [INCH]
- GENERAL TOLERANCE: X.X = ±0.4
X.XX = ±0.25
- TERM. NOS. FOR REF. ONLY
- RATING: 15A @ 125VAC
8A @ 250VAC
- LAMP VOLTAGE: NO LAMP
- TERMINAL/CONTACTS: SILVER PLATED
- ELECTRICAL LIFE: 10,000 CYCLES
- CONTACT RESISTANCE: <20 MILLI-OHMS INITIAL
- DIELECTRIC STRENGTH: >1,500V AC 1 MIN
- ▲ DENOTES CRITICAL PARAMETER.

REV	ECO NO	DESCRIPTION	DATE	BY	E-SWITCH®			OBJECT ID	
C	ECO-101954	update housing	06/08/23	MW	TITLE R1966ABLKBLKFS			000016576	
THE INFORMATION CONTAINED IN THIS DOCUMENT IS PROPRIETARY TO E-SWITCH AND IS NOT TO BE COPIED OR TRANSFERRED					SCALE	DATE	DR	DWG	REV
					3:2	9/19/1991	CB	M301207	C