

RECOMMENDED PANEL MOUNTING

PANEL THICKNESS	X± 0.05
0.75-1.25	29.65
1.25-2.00	30.15
2.00-3.00	30.50

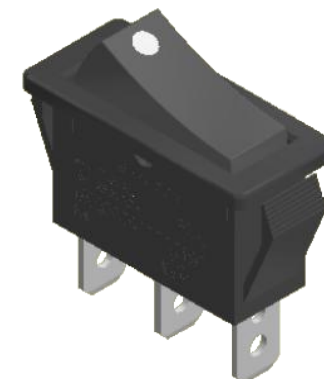

SWITCH FUNCTION		G
POS. 1	POS. 3	
ON	ON	
1-1a	1-1b	

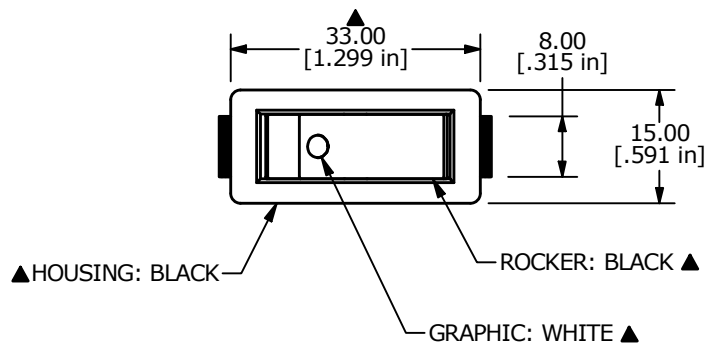
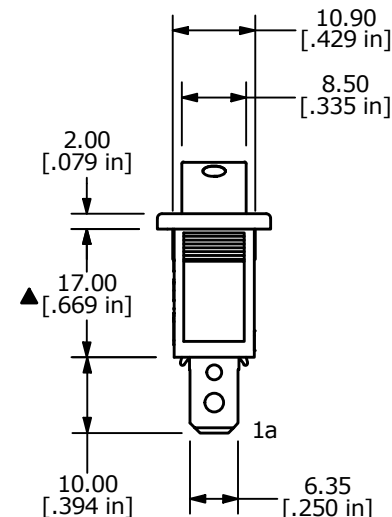
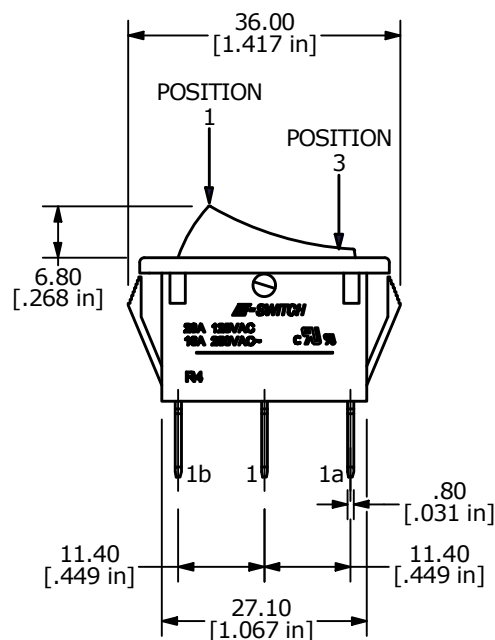
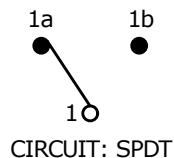

NOTES:

- ALL DIMENSIONS IN MM [INCH]
- GENERAL TOLERANCE: X.X=± 0.4  
X.XX=± 0.25
- TERM. NOS. FOR REF. ONLY
- RATING: 20A 125VAC, 16A 250VAC UL APPROVED
- ELECTRICAL LIFE: OVER 10,000 CYCLES
- MECHANICAL LIFE: OVER 30,000 CYCLES
- CONTACT RESISTANCE: <20 mΩ(INITIAL)
- DIELECTRIC STRENGTH: >1500V 1 min
- INSULATION RESISTANCE: >1,000 mΩ @ 500V DC
- OPERATING TEMPERATURE: TERMINAL SIDE -20°C to 85°C  
ROCKER SIDE -20°C to 55°C
- ▲ DENOTES CRITICAL PARAMETER

REV	ECO NO	DESCRIPTION	DATE	BY
H	ECO-100502	REMOVE VDE/ENEC RATING AND LOGO	01/28/22	JS



OBJECT ID  
000016385

TITLE R4CBLKBLKAF0		SCALE 1:1	DATE 3/20/2006	DR RC	DWG M040122	REV H
-----------------------	--	--------------	-------------------	----------	----------------	----------