

RECOMMENDED PANEL MOUNTING

PANEL THICKNESS	X
0.75-1.25	30.0-30.2
1.25-2.00	30.2-30.4
2.00-3.00	30.6-30.8

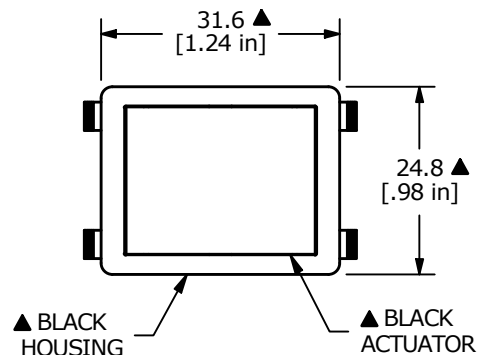

SWITCH FUNCTION		
POS. 1	POS. 2	POS. 3
ON	OFF	ON
1-1b, 2-2b	NONE	1-1a, 2-2a

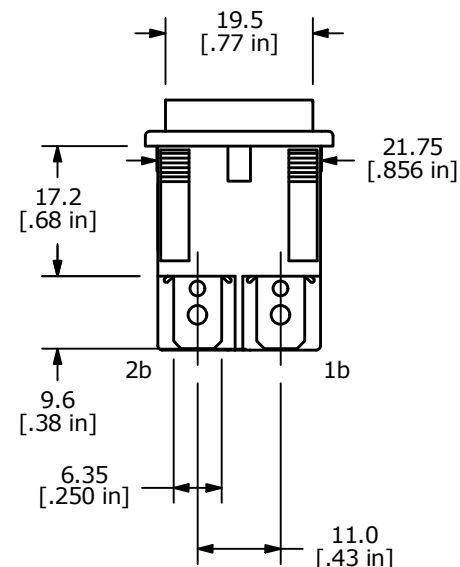
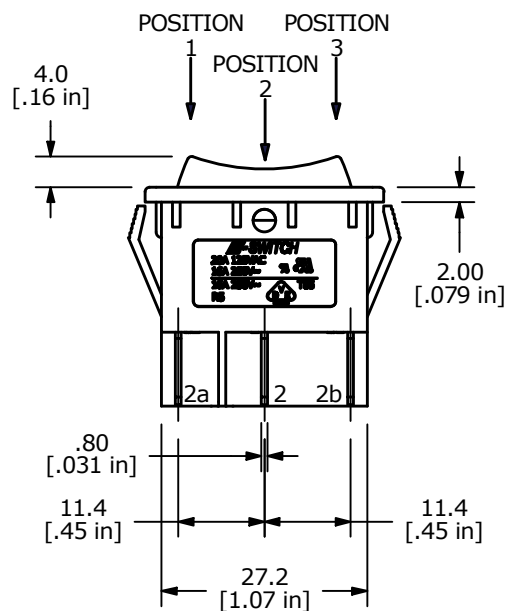
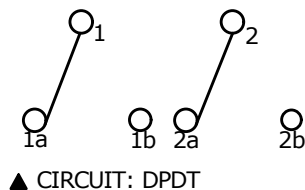

NOTES:

1. ALL DIMENSIONS IN MM [INCH]
2. GENERAL TOLERANCE: X.X=±0.4
X.XX=±0.25
3. TERM. NOS. FOR REF. ONLY
- ▲ 4. RATING: 10A @250VAC UL APPROVED
15A @125VAC UL APPROVED
16A @250VAC VDE APPROVED
5. ELECTRICAL LIFE: 10,000 CYCLES
6. MECHANICAL LIFE: 30,000 CYCLES
7. CONTACT RESISTANCE: <20 MILLI-OHMS INITIAL
8. DIELECTRIC STRENGTH: >1,500V AC 1MIN
9. INSULATION RESISTANCE: >1000MOHMS
10. OPERATING TEMP: TERMINAL SIDE: -20°C to 85°C
ROCKER SIDE: -20°C to 55°C
11. ▲ DENOTES CRITICAL PARAMETER.

REV	ECO NO	DESCRIPTION	DATE	BY	E-SWITCH®			OBJECT ID	
G	ECO-101575	PRINT UPDATE	01/30/23	JS				000016436	
					TITLE R5DBLKBLKEF0				
					SCALE 1:1	DATE 3/23/2011	DR BMA	DWG M050205	REV G

THE INFORMATION CONTAINED IN THIS DOCUMENT IS PROPRIETARY TO E-SWITCH AND IS NOT TO BE COPIED OR TRANSFERRED