

SUGGESTED PANEL CUTOUT

PANEL THICKNESS	(X) +.10mm/-0.00mm
1.5 - 2.0 mm	36.8 mm
2.0 - 3.0 mm	37.2 mm
3.0 - 4.0 mm	37.5 mm

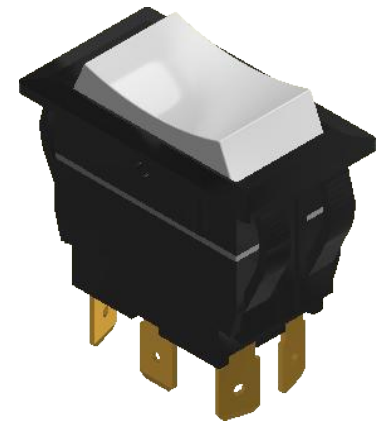

SWITCH FUNCTION		
POS. 3	POS. 2	POS. 1
ON	OFF	ON
2-1, 5-4	OPEN	2-3, 5-6

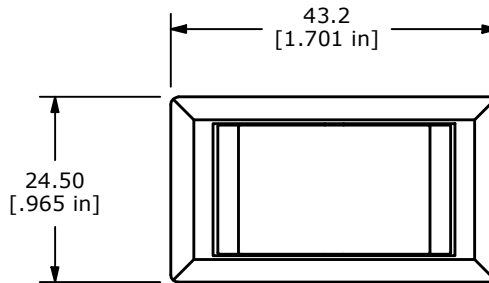
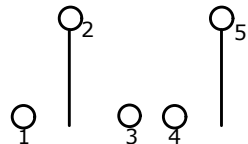

▲ CIRCUIT: DPDT  
ON - OFF - ON  
MAINTAINED

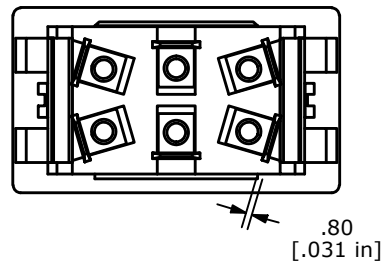
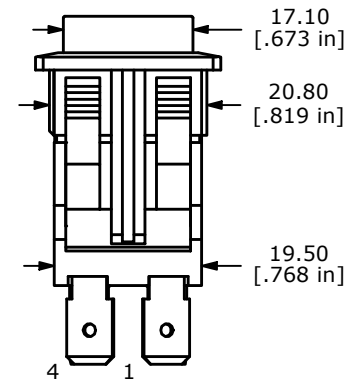
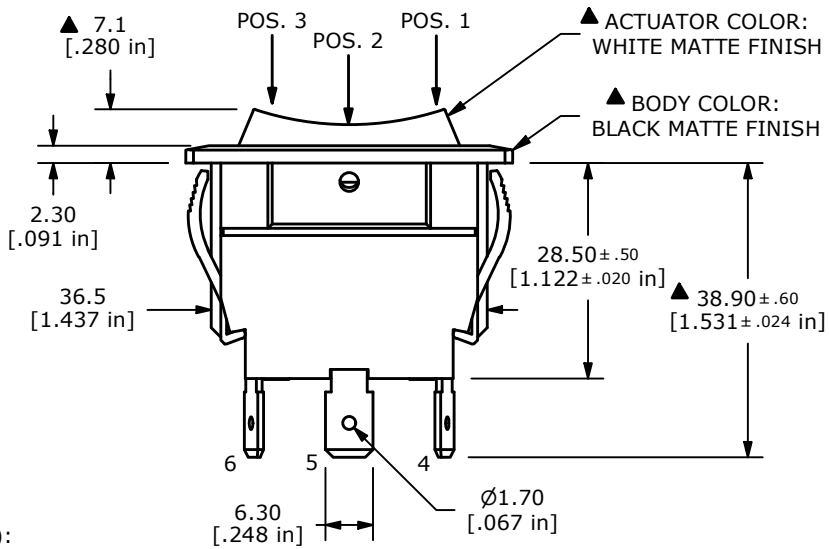

▲ ACTUATOR COLOR:  
WHITE MATTE FINISH

▲ BODY COLOR:  
BLACK MATTE FINISH

NOTES:

- ALL DIMENSIONS IN MM [INCH]
- GENERAL TOLERANCE: X.X=± 0.5  
X.XX=± 0.3
- RATINGS: ANSI/UL 508 AND CAN/CSA C22.2 NO.14 (E195908):  
20A, 125VAC [cURus]  
15A, 277VAC [cURus]  
2HP, 110/250VAC [cURus]
- CONTACT RESISTANCE: 50 mΩ MAX. @ 50VAC
- INSULATION RESISTANCE: 2 MΩ MIN. @ 500VDC
- OPERATING TEMPERATURE: 0°C TO +55°C [cURus, CSA]  
0°C TO +55°C [VDE]
- ELECTRICAL LIFE: 6,000 CYCLES [cURus]
- DIELECTRIC STRENGTH: 1,500V FOR 1 MINUTE
- INGRESS PROTECTION: IP54
- ▲ DENOTES CRITICAL PARAMETER

D	24681	UPDATED DIMENSIONS, CUTOUT, NOTES	3/16/21	JM
C	22499	UPDATED NOTES	5/11/17	MJR
B	00247	CORRECTED SPECIFICATIONS	12/9/09	CAB
REV	PCR NO	DESCRIPTION	DATE	BY

THE INFORMATION CONTAINED IN THIS DOCUMENT IS PROPRIETARY TO E-SWITCH AND IS NOT TO BE COPIED OR TRANSFERRED



TITLE RVW46D1200				
SCALE 1:1	DATE 8/5/2009	DR CAB	DWG 34-RVW46D1200	REV D