

RECOMMENDED PANEL CUT OUT

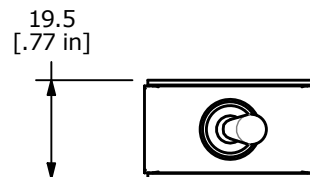

▲ SWITCH FUNCTION		
POS. 1	POS. 2	POS. 3
OFF	N/A	ON
OPEN	N/A	1-2, 4-5

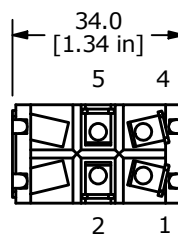
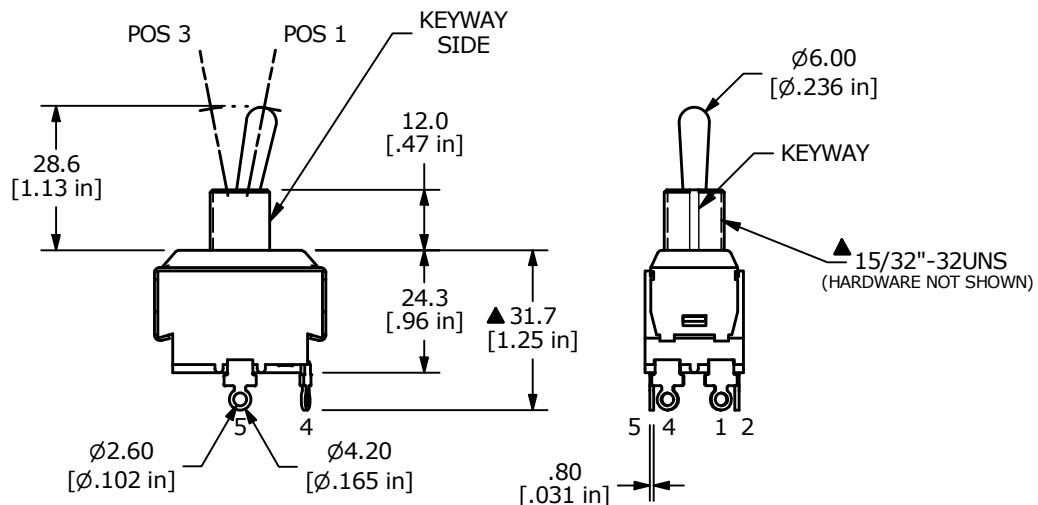

NOTES:

1. ALL DIMENSIONS IN MM
2. GENERAL TOLERANCE: X.X = ±0.5
X.XX = ±0.25
3. TERM. NOS. FOR REFERENCE ONLY
4. ELECTRICAL LIFE: 6,000 CYCLES
5. OPERATING TEMP: 0°C to 85°C
6. CONTACT RESISTANCE: 50mΩ MAX. INITIAL
7. INSULATION RESISTANCE: 2MΩ AT 500VDC
8. DIELECTRIC STRENGTH: 1000VAC FOR 1 MINUTE
9. ▲ DENOTES CRITICAL PARAMETER
10. CONTACT RATING: 20A 125VAC,
15A 277VAC
2HP 125/277VAC
- ▲ 11. SUPPLIED HARDWARE: 2 HEXNUTS

REV	ECO NO	DESCRIPTION	DATE	BY	E-SWITCH®	OBJECT ID
A	ECO-101634	RELEASE	02/13/23	JS		100123597
					TITLE	ST222D02
			SCALE	DATE	DR	REV
			2:3	2/6/2023	JS	A
					DWG	34-ST222D02