

RECOMMENDED PANEL CUT-OUTS

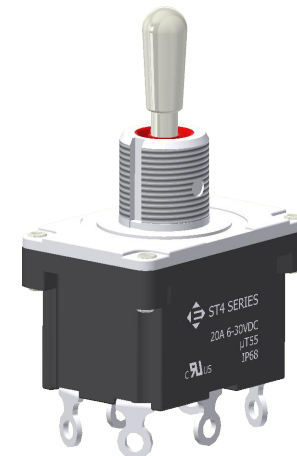
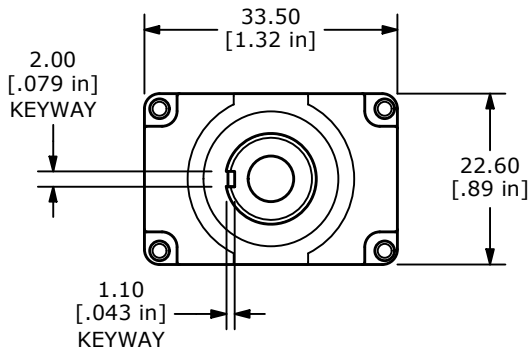

SWITCH FUNCTION		
POS. 1	POS. 2	POS. 3
ON	OFF	(ON)
1-2, 4-5	OPEN	(2-3), (5-6)

(ON) = MOMENTARY

NOTES:

1. ALL DIMENSIONS IN MM [INCH]
2. GENERAL TOLERANCE: X.X = ±0.4
X.XX = ±0.25
3. TERM. NUMBERS FOR REF. ONLY
- ▲ 4. RATING: 20A 6-30VDC µT55
5. ELECTRICAL LIFE: 10,000 CYCLES
6. CONTACT RESISTANCE: <20 MILLI-OHMS INITIAL
7. DIELECTRIC STRENGTH: >1,500V AC 1MIN
8. INSULATION RESISTANCE: >100MOHMS
9. OPERATING TEMP: -10°C to 55°C
10. INGRESS PROTECTION: IP68
11. ▲ DENOTES CRITICAL PARAMETER.
12. SUPPLIED HARDWARE: LOCK WASHER and TWO HEXNUTS

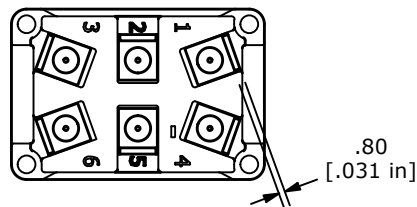
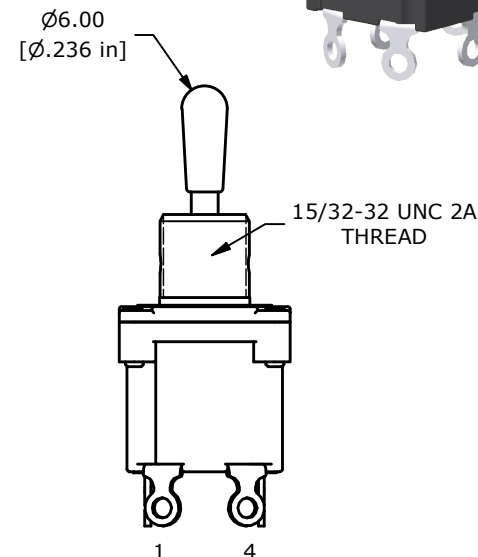
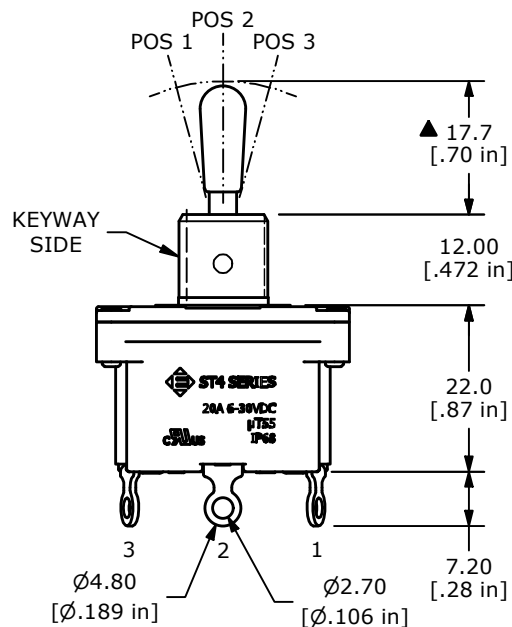

REV	ECO NO	DESCRIPTION	DATE	BY
A	ECO-102894	RELEASE	08/06/24	JS



OBJECT ID
100127998

TITLE ST4DP9DT1S1				
SCALE 1:1	DATE 7/30/2024	DR JS	DWG 14-ST4DP9DT1S1	REV A