

RECOMMENDED PANEL CUTOUT  
MAX. PANEL THICKNESS 1-6mm

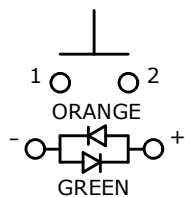

SCHMATIC  
SPST - OFF-(ON)  
( ) DENOTES MOMENTARY

NOTE:

1. ALL DIMENSIONS IN MM [INCH]
2. GENERAL TOLERANCE: X.X = ±0.4  
X.XX = ±0.25
3. TERMINAL NUMBERS FOR REF ONLY
4. CONTACTS: BRASS, COIN SILVER, GOLD FLASH
5. TERMINALS: GOLD FLASH PLATED
6. RATING: 2A 36 VDC
7. ELECTRIC LIFE: 200,000 CYCLES
8. DIELECTRIC STRENGTH: 2,000 VAC MIN. FOR 1 MINUTE
9. CONTACT RESISTANCE: 50mΩ MAX. @ 1A 12VDC
10. OPERATING TEMP.: -20°C to 70°C
11. ▲ DENOTES CRITICAL PARAMETER.
- ▲ 12. LAMP VOLTAGE: ORANGE 20mA 2.0V TYP., GREEN 20mA 3.1V TYP.
13. TRAVEL: 1.80mm
14. ACTUATION FORCE: 4.5 ± 1.5 N
15. MOUNTING NUT TORQUE: 1-3 Nm
16. INGRESS PROTECTION: IP67, IK10
17. HARDWARE SUPPLIED: O-RING AND HEXNUT

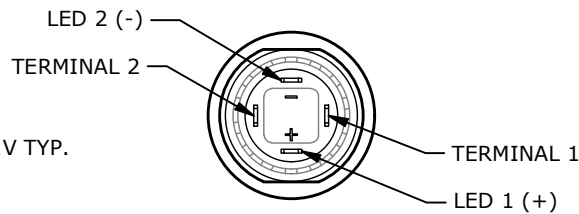
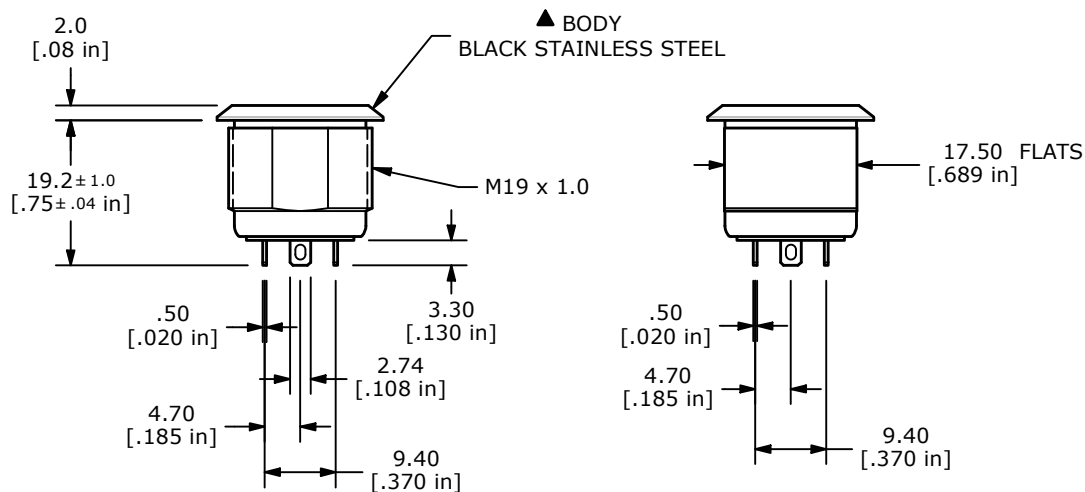
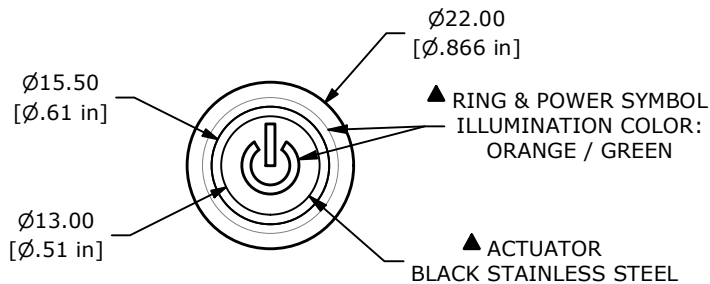

REV	ECO NO	DESCRIPTION	DATE	BY
A	ECO-103509	Release	09/05/25	MR



OBJECT ID  
100130509

TITLE SV4F23SS-6K1				
SCALE 1:1	DATE 6/30/2025	DR MW	DWG T840017	REV A