

NOTES:

1. ALL DIMENSIONS IN MM
2. GENERAL TOLERANCE: X.X=±0.4
X.XX=±0.2
3. TERMINAL NUMBERS. FOR REFERENCE ONLY.
4. RATING: 50mA, 12VDC
- ▲ 5. OPERATING FORCE: 260 ± 50gf
6. TRAVEL: 0.15mm ± 0.1
7. CONTACT RESISTANCE: 100mΩ MAX.
- ▲ 8. CONTACT MATERIAL: SILVER
9. DIELECTRIC STRENGTH: 250VAC FOR 1 MIN
10. INSULATION RESISTANCE: 100MΩ @ 100VDC
11. MECHANICAL/ELECTRICAL LIFE 100,000 CYCLES MIN.
12. ▲ DENOTES CRITICAL PARAMETER
13. OPERATING TEMPATURE: -25C to +70C
14. PACKING: TAPE & REEL

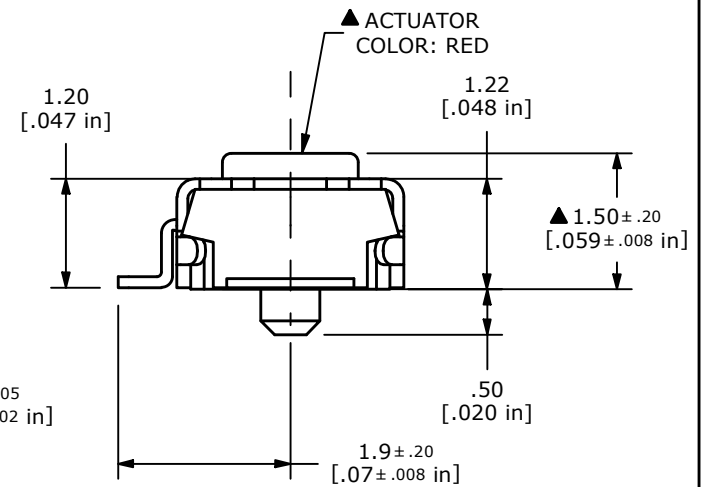

REV	ECO NO	DESCRIPTION	DATE	BY
C	ECO-102134	NOTE 14 REMOVED QUANTITY PER REEL	08/09/23	JS
B	ECO-101673	PACKING NOTE 4,000 PCS/REEL WAS 3,000	02/16/23	JS
A	ECO-101568	RELEASE	02/06/23	JS

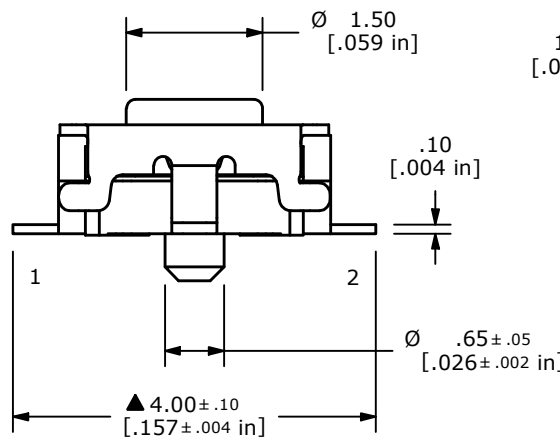

OBJECT ID
100123464

TITLE TL1017ABBF260QG		SCALE 12:1	DATE 1/13/2023	DR JS	DWG P620008	REV C
-----------------------	--	------------	----------------	-------	-------------	-------