

P.C.B. LAYOUT

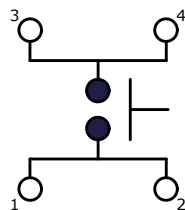

CIRCUIT: SPST ▲

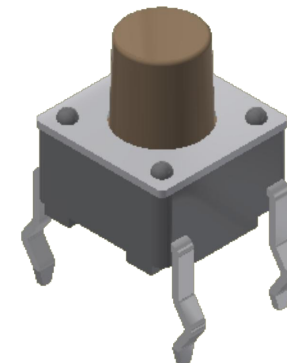
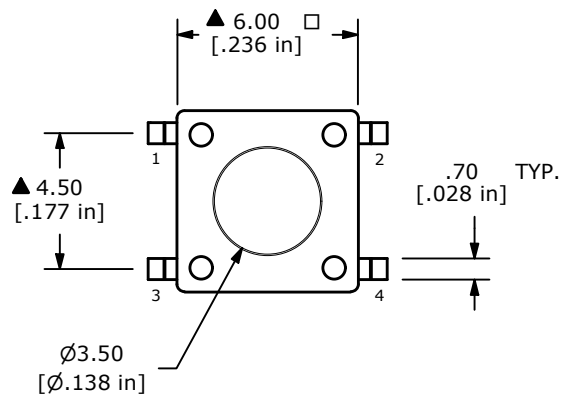

ACTUATOR
COLOR: BROWN

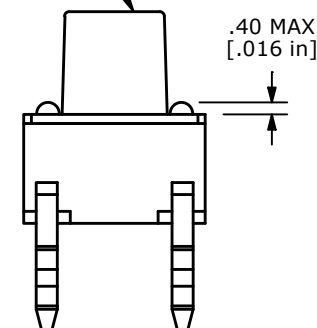
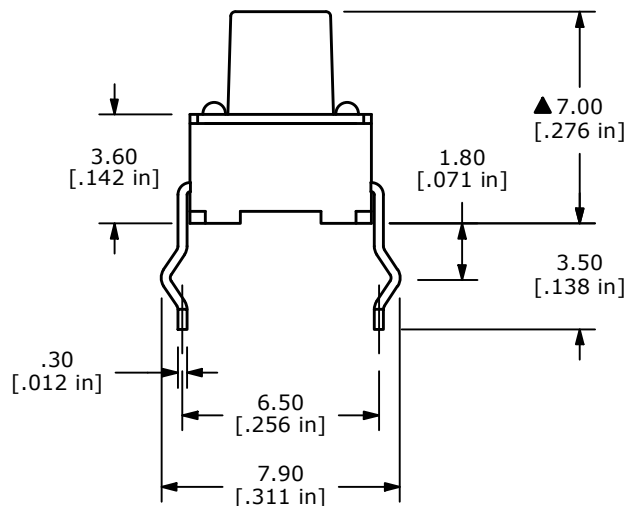

NOTES:

1. ALL DIMENSIONS IN MM
2. GENERAL TOLERANCE: X.X=±0.4
X.XX=±0.25
3. TERM. NOS. FOR REFERENCE ONLY.
4. RATING: 12VDC, 50mA
- ▲ 5. OPERATING FORCE: 100 ± 30 gf
6. TRAVEL: 0.25mm +0.20/-0.10MM
7. CONTACT RESISTANCE: 100 MILLI OHMS MAX. (INITIAL)
8. MECHANICAL/ELECTRICAL LIFE 100,000 CYCLES MIN.
- ▲ 9. CONTACT MATERIAL: SILVER
10. ▲ DENOTES CRITICAL PARAMETER
11. OPERATING TEMP: -40°C TO 85°C

| REV | ECO NO | DESCRIPTION | DATE | BY |  | | | OBJECT ID | |
|---|------------|------------------------------------|----------|----|---|----------|-----|--------------------|-----|
| C | ECO-102176 | PRINT UPDATE, NOTE 5 +/- 30 WAS 50 | 08/31/23 | JS | | | | TITLE TL1105FF100Q | |
| <p style="font-size: small; text-align: center;">THE INFORMATION CONTAINED IN THIS DOCUMENT IS PROPRIETARY TO E-SWITCH AND IS NOT TO BE COPIED OR TRANSFERRED</p> | | | | | SCALE | DATE | DR | DWG | REV |
| | | | | | 4:1 | 8/1/2001 | CJB | P010027 | C |