

CIRCUIT: SPST ▲

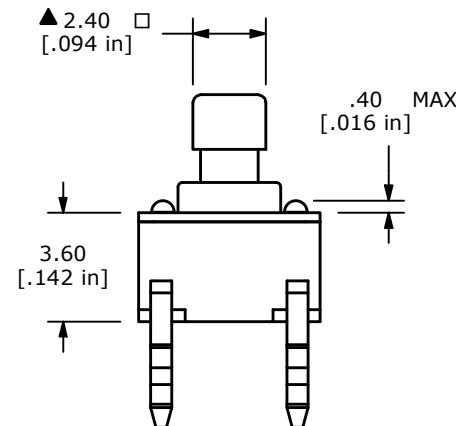
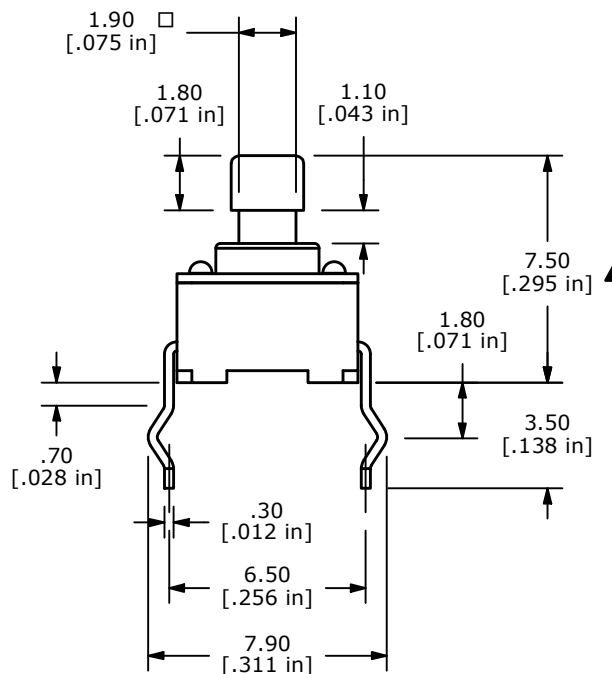

- NOTES:
1. ALL DIMENSIONS IN MM [INCH]
 2. TERMINAL NUMBERS FOR REF. ONLY
 3. TOLERANCE: X.X=± 0.4
X.XX=± 0.25
 4. RATING: 50mA @ 12VDC
 5. TRAVEL: 0.25 +0.2/-0.1mm
 - ▲ 6. OPERATING FORCE: 160± 50gf
 7. ELECTRICAL LIFE: 100,000 CYCLES MIN.
 8. CONTACT RESISTANCE: 100mΩ MAX.
 - ▲ 9. CONTACT MATERIAL: SILVER
 10. ▲ DENOTES CRITICAL PARAMETER
 11. OPERATING TEMP: -40°C TO 85°C

REV	ECO NO	DESCRIPTION	DATE	BY	E-SWITCH®			OBJECT ID	
C	ECO-102235	PRINT UPDATE	09/21/23	JS	TITLE TL1105TF160Q			000017711	
THE INFORMATION CONTAINED IN THIS DOCUMENT IS PROPRIETARY TO E-SWITCH AND IS NOT TO BE COPIED OR TRANSFERRED					SCALE	DATE	DR	DWG	REV
					4:1	5/19/1999	MM	P010228	C