

SWITCH FUNCTION	
POS. 1	POS. 2
ON	ON
2-1, 5-4	2-3, 5-6

(ON)=MOMENTARY

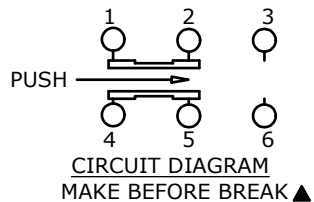

NOTES:

1. ALL DIMENSIONS IN MM [INCH]
2. GENERAL TOLERANCE: X.X=± 0.4
X.XX=± 0.25
3. TERMINAL NUMBERS FOR REF. ONLY
- ▲ 4. RATING: 0.1A @ 30VDC
5. TRAVEL: 2.50± 0.38mm
6. OPERATING FORCE: 220± 50gf
7. ELECTRICAL LIFE: 10,000 CYCLES
8. ▲ DENOTES CRITICAL PARAMETER
9. 2002/95/EC (RoHS) COMPLIANT

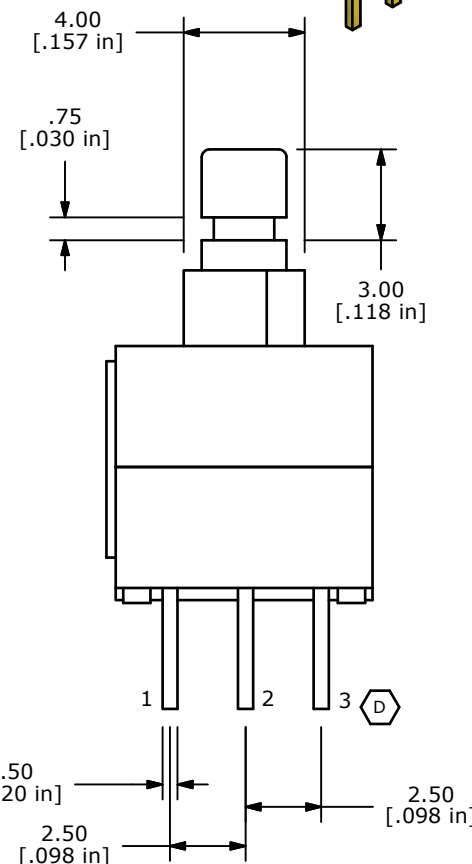
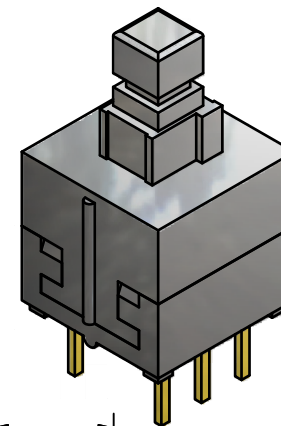
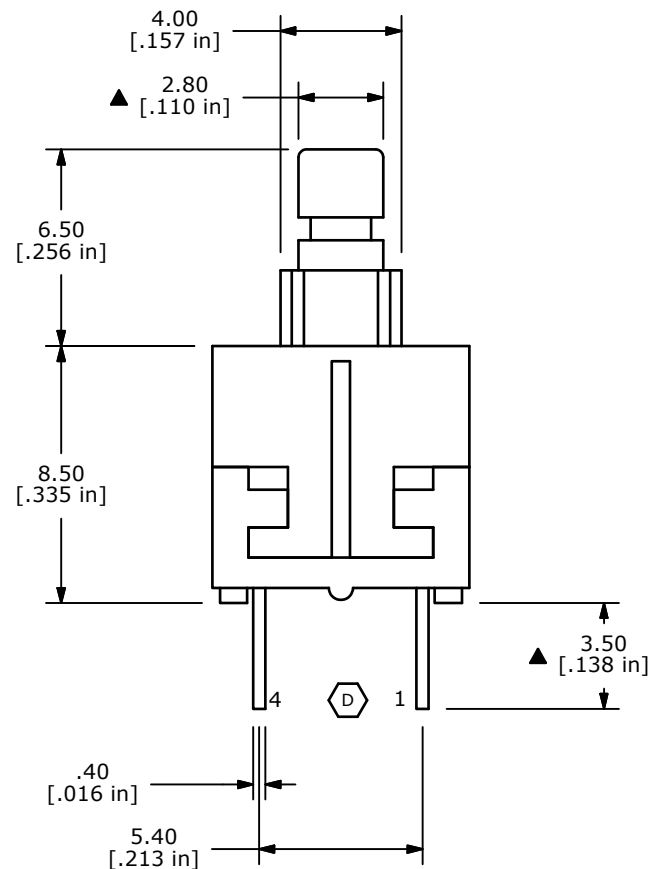
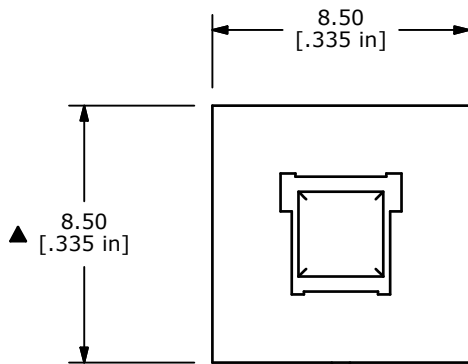

D	19364	CORRECT CONTACT NUMBERING	10/19/10	BMA
C	18032	Redrawn and chg force from 180 grams	3/19/08	RC
REV	PCR NO	DESCRIPTION	DATE	BY

THE INFORMATION CONTAINED IN THIS DOCUMENT IS PROPRIETARY TO E-SWITCH AND IS NOT TO BE COPIED OR TRANSFERRED

TITLE TL2201EEZA				
SCALE 4:1	DATE 3/19/2008	DR RC	DWG P010352	REV D