

- NOTES:**
1. ALL DIMENSIONS IN MM [INCH]
 2. GENERAL TOLERANCE: X.X = ±0.4
X.XX = ±0.25
 3. CONTACT RATING: 50mA @ 12VDC
 4. CONTACT RESISTANCE: 100 mΩ MAX.
 5. INSULATION RESISTANCE: 100MΩ MIN @ 500VDC.
 - ▲ 6. OPERATING FORCE: 100 ± 50gf
 7. TRAVEL: 0.2 ± 0.1mm
 8. OPERATING TEMPERATURE: -25°C to +70°C
 9. OPERATING LIFE: 500,000 CYCLES
 - ▲ 10. LED: BLUE
 11. ▲ DENOTES CRITICAL PARAMETERS
 12. 2011/65/EU (ROHS) COMPLIANT
 13. PARTS TO BE PACKAGED IN TAPE & REEL, 450 PIECES PER REEL

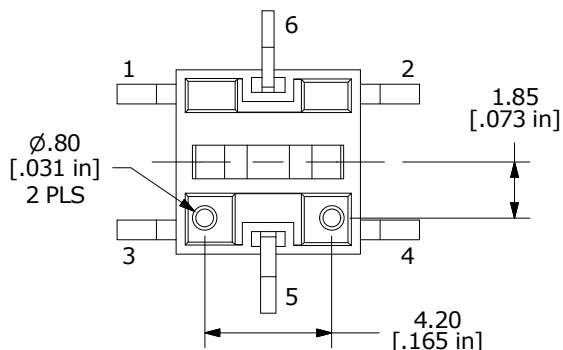

▲ LED SPECS	UNITS	BLUE
FORWARD CURRENT	mA	20
FORWARD VOLTAGE @20mA	V	3.0 TYP; 3.6 MAX
LUMINOUS INTENSITY @ 20mA	mcd	1100 TYP

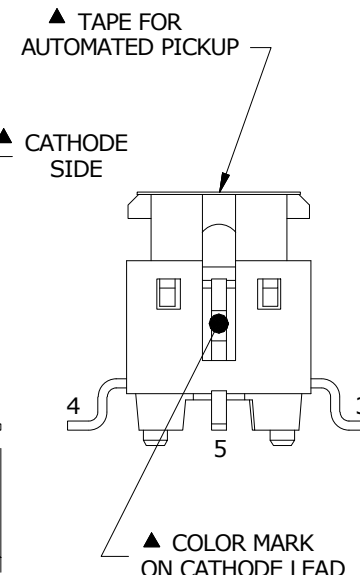
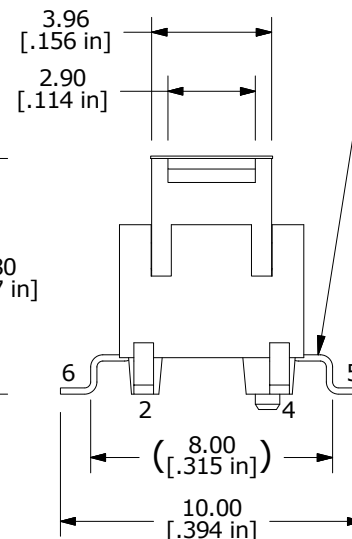
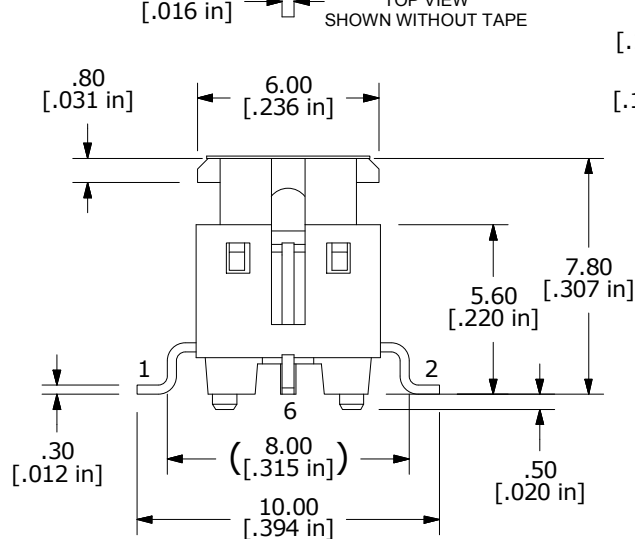
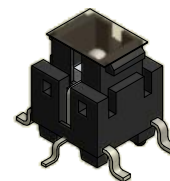
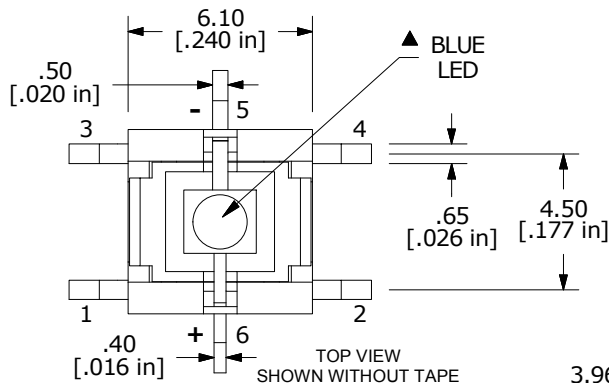

A	22950	Release For Production	8/7/17	MW
REV	PCR NO	DESCRIPTION	DATE	BY

TITLE TL3240F100BT				
SCALE	DATE	DR	DWG	REV
4:1	8/4/2017	MW	N324026	A

THE INFORMATION CONTAINED IN THIS DOCUMENT IS PROPRIETARY TO E-SWITCH AND IS NOT TO BE COPIED OR TRANSFERRED