

RECOMMENDED P.C.B. LAYOUT

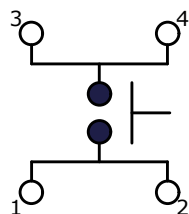

CIRCUIT: SPST

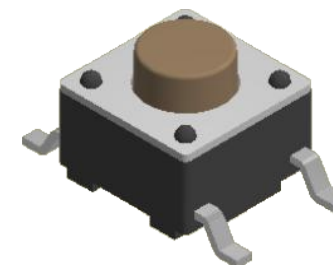
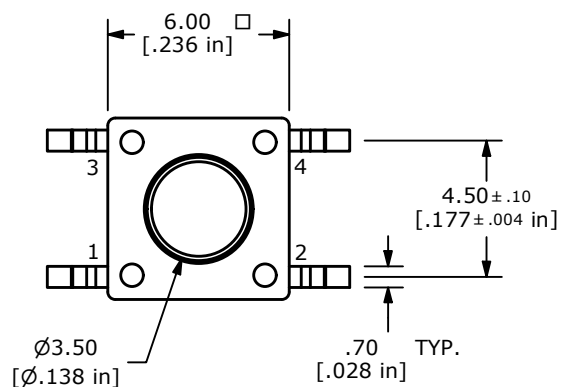
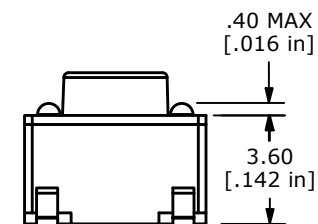
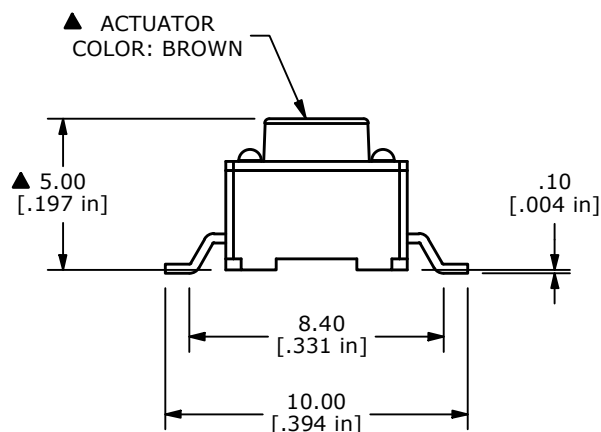

▲ ALL TERMINALS MUST BE COPLANAR WITHIN 0.10 [.004 in]

NOTES:

1. ALL DIMENSIONS IN MM
2. GENERAL TOLERANCE: X.X=±0.4  
X.XX=±0.25
3. TERM. NUMBERS FOR REFERENCE ONLY.
4. RATING: 50VDC, 50mA
- ▲ 5. OPERATING FORCE: 100 ± 50 gf
6. TRAVEL: 0.25mm +0.2/-0.1mm
7. CONTACT RESISTANCE: 100 MILLI OHMS MAX. (INITIAL)
8. MECHANICAL/ELECTRICAL LIFE 100,000 CYCLES MIN.
- ▲ 9. CONTACT MATERIAL: SILVER
- ▲ 10. PACKAGE: TAPE AND REEL, 1,200 PIECES PER REEL
11. ▲ DENOTES CRITICAL PARAMETER
12. OPERATING TEMP: -40°C TO 85°C

E	24699	CHANGE OPERATING TEMP	2/3/21	JM
D	20881	Act color was Black	11/14/12	RC
C	20773	REVISED AND REDRAWN	9/25/12	RC
REV	PCR NO	DESCRIPTION	DATE	BY



TITLE TL3301AF100QG				
SCALE	DATE	DR	DWG	REV
4:1	7/29/2002	RC	P010529	E

THE INFORMATION CONTAINED IN THIS DOCUMENT IS PROPRIETARY TO E-SWITCH AND IS NOT TO BE COPIED OR TRANSFERRED