

▲ CIRCUIT: SPST

▲ ALL TERMINALS MUST BE COPLANAR WITHIN 0.10MM TOTAL

▲ ACTUATOR COLOR: BLACK

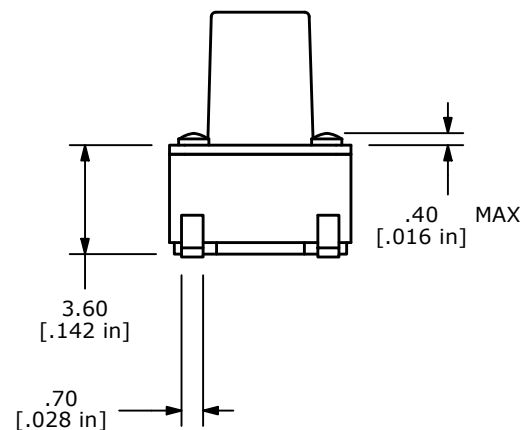
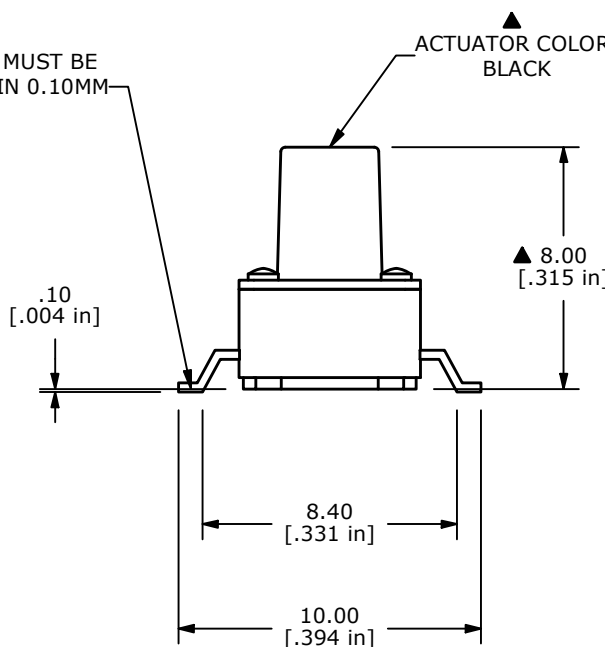

NOTES:

1. ALL DIMENSIONS IN MM
2. GENERAL TOLERANCE: X.X=±0.4  
X.XX=±0.25
3. TERM. NOS. FOR REFERENCE ONLY.
4. RATING: 12VDC, 50mA
5. OPERATING FORCE: 160 ± 50 gf
6. TRAVEL: 0.25mm ±0.1
7. CONTACT RESISTANCE: 100 MILLI OHMS MAX. (INITIAL)
8. MECHANICAL/ELECTRICAL LIFE 100,000 CYCLES MIN.
9. CONTACT MATERIAL: SILVER
10. ▲ DENOTES CRITICAL PARAMETER
11. PACKAGING: TAPE AND REEL, 700 PIECES PER REEL
12. OPERATING TEMP: -40°C TO 85°C



B	24731	CHANGE OPERATING TEMP	3/1/21	JM
A	20787	NEW RELEASE	9/28/12	RC
REV	PCR NO	DESCRIPTION	DATE	BY

TITLE TL3301CF160QG				
SCALE 4:1	DATE 9/28/2012	DR RC	DWG J100502	REV B

THE INFORMATION CONTAINED IN THIS DOCUMENT IS PROPRIETARY TO E-SWITCH AND IS NOT TO BE COPIED OR TRANSFERRED