

- NOTES:
1. ALL DIMENSIONS IN MM
 2. GENERAL TOLERANCE: X.X=±0.4
X.XX=±0.25
 3. TERM. NOS. FOR REFERENCE ONLY.
 4. RATING: 12VDC, 50mA
 5. OPERATING FORCE: 260 ± 50 gf
 6. TRAVEL: 0.25mm ±0.1
 7. CONTACT RESISTANCE: 100 MILLI OHMS MAX. (INITIAL)
 8. MECHANICAL/ELECTRICAL LIFE 100,000 CYCLES MIN.
 9. CONTACT MATERIAL: SILVER
 10. ▲ DENOTES CRITICAL PARAMETER
 11. PACKAGING: TAPE AND REEL, 300 PIECES PER REEL
 12. OPERATING TEMP: -40°C TO 85°C

▲ ALL TERMINALS MUST BE COPLANAR WITHIN 0.10MM TOTAL

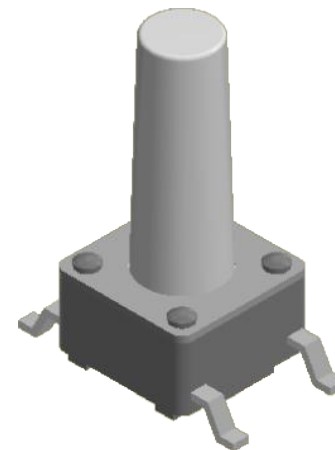

▲ ACTUATOR COLOR: WHITE

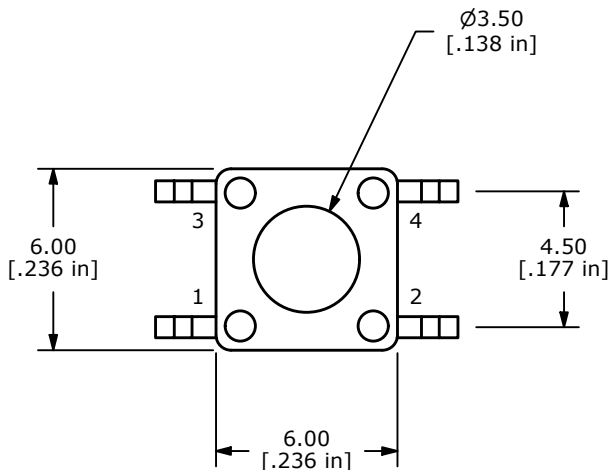
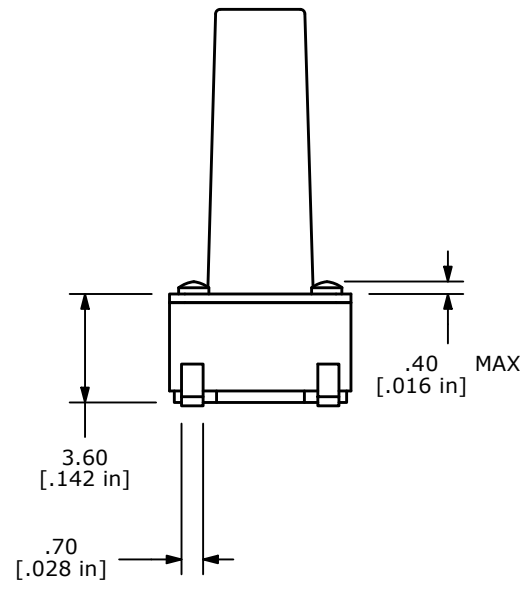
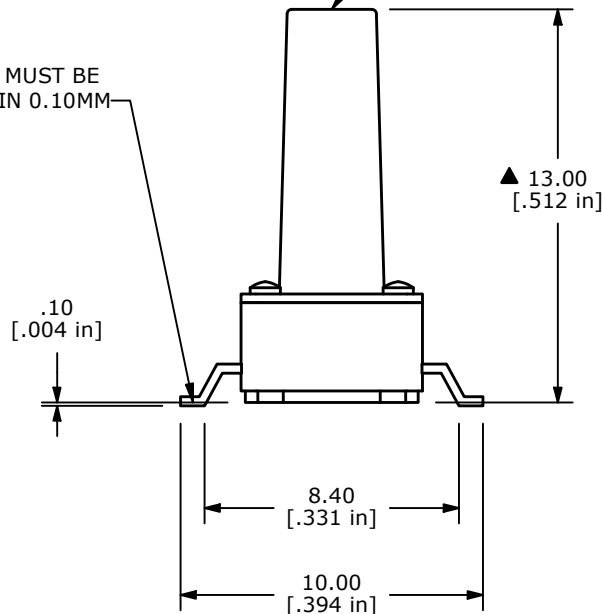

B	24731	CHANGE OPERATING TEMP	3/1/21	JM
A	20795	NEW RELEASE	10/1/12	RC
REV	PCR NO	DESCRIPTION	DATE	BY

TITLE TL3301DF260QG				
SCALE	DATE	DR	DWG	REV
4:1	10/1/2012	RC	J100614	B

THE INFORMATION CONTAINED IN THIS DOCUMENT IS PROPRIETARY TO E-SWITCH AND IS NOT TO BE COPIED OR TRANSFERRED