

USE GOLD DOME
P990006

ACTUATOR COLOR:
BROWN

TERMINALS TO BE COPLANAR
WITHIN 0.10mm

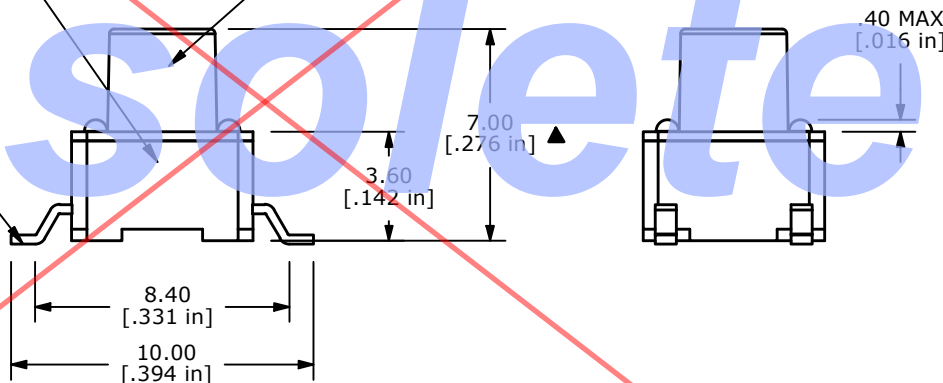

NOTES:

1. ALL DIMENSIONS IN MM
2. GENERAL TOLERANCE: X.X=±0.4
X.XX=±0.25
3. TERM. NOS. FOR REFERENCE ONLY.
4. RATING: 50mA @ 12 VDC
- ▲ 5. OPERATING FORCE: 100 ± 50 GF
6. TRAVEL: 0.25MM +0.2/-0.1MM
7. CONTACT RESISTANCE: 100 MILLI OHMS MAX. (INITIAL)
8. MECHANICAL/ELECTRICAL LIFE 100,000 CYCLES MIN.
- ▲ 9. GOLD CONTACTS
- ▲ 10. PACKAGE: 700 PCS PER TAPE AND REEL
11. ▲ DENOTES CRITICAL PARAMETER
12. 2002/95/EC (ROHS) COMPLIANT



TITLE TL3301FF100RG

A	21075	NEW RELEASE	3/20/13	EBP
REV	PCR NO	DESCRIPTION	DATE	BY

SCALE	DATE 3/20/2013	DR EBP	DWG P010833	REV A
-------	-------------------	-----------	----------------	----------

THE INFORMATION CONTAINED IN THIS DOCUMENT IS PROPRIETARY
TO E-SWITCH AND IS NOT TO BE COPIED OR TRANSFERRED