

▲ CIRCUIT: SPST

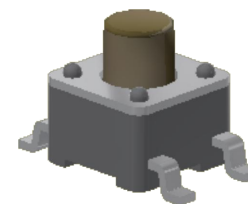

NOTES:

1. ALL DIMENSIONS IN MM
2. GENERAL TOLERANCE: X.X = ±0.4
X.XX = ±0.25
3. TERM. NOS. FOR REFERENCE ONLY.
4. CONTACT MATERIAL: SILVER
5. RATING: 12VDC, 50mA
- ▲ 6. OPERATING FORCE: 100 ±30gf
7. TRAVEL: 0.20 ±0.10mm
8. CONTACT RESISTANCE: 100 MILLI OHMS MAX. (INITIAL)
9. MECHANICAL/ELECTRICAL LIFE: 500,000 CYCLES MIN.
10. INSULATION RESISTANCE: 100M OHMS MIN @ 100VDC
11. DIELECTRIC STRENGTH: 250VAC
12. OPERATING TEMPERATURE: -20°C to +70°C
13. STORAGE TEMPERATURE: -30°C to +80°C
14. ▲ DENOTES CRITICAL PARAMETER
15. PACKAGING: TAPE AND REEL, 1500 PIECES PER REEL.

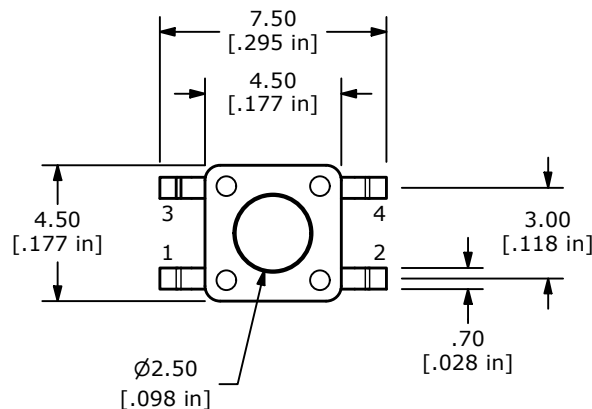
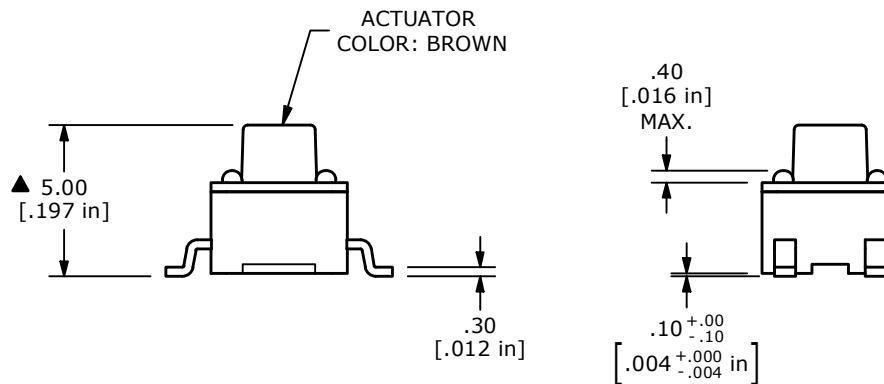

REV	ECO NO	DESCRIPTION	DATE	BY
A	ECO-102892	Release	07/31/24	MW



OBJECT ID
100127984

TITLE TL3305BF100QG				
SCALE	DATE	DR	DWG	REV
4:1	7/30/2024	MW	P010476	A