

- NOTES:
1. ALL DIMENSIONS IN MM [INCH]
 2. GENERAL TOLERANCE: X.X=±0.4
X.XX=±0.25
 3. CONTACT RATING: 50mA @ 12VDC
 4. CONTACT RESISTANCE: 100mΩ MAX.
 5. INSULATION RESISTANCE: 100MΩ MIN @ 500VDC.
 - ▲ 6. OPERATING FORCE: 185 ± 50gf
 7. TRAVEL: 0.15 mm MINIMUM
 8. OPERATING TEMPERATURE: -40°C TO + 85°C
 - ▲ 9. OPERATING LIFE: 200,000 CYCLES
 10. CONTACTS: SILVER
 11. ▲ DENOTES CRITICAL PARAMETERS
 12. PACKAGE: TAPE AND REEL - 600 PIECES PER REEL

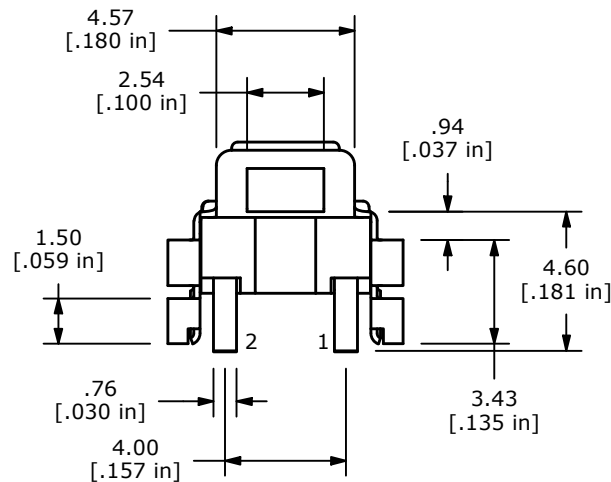

REV	ECO NO	DESCRIPTION	DATE	BY
F	ECO-103901	PRINT UPDATE	01/23/26	JS

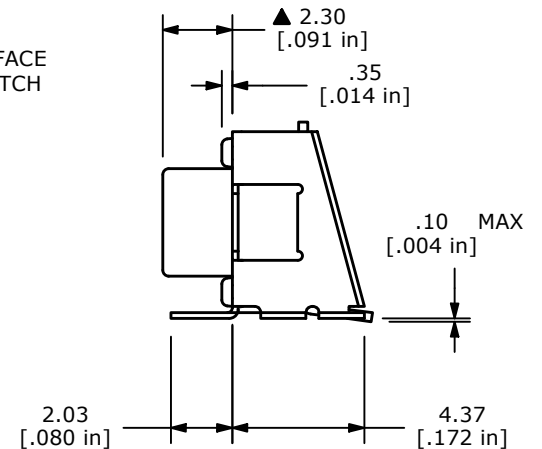
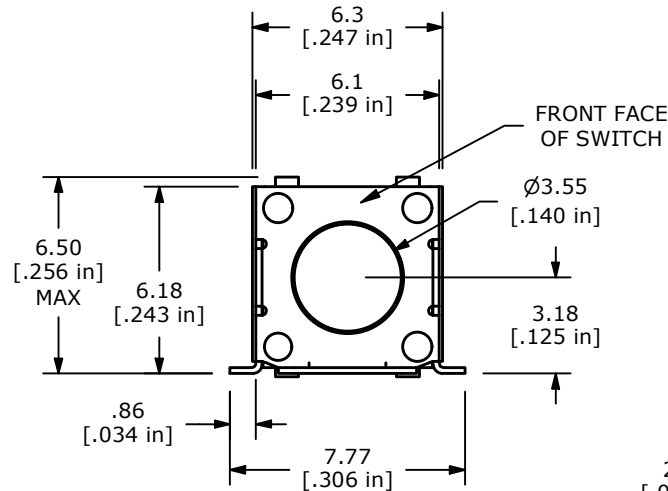
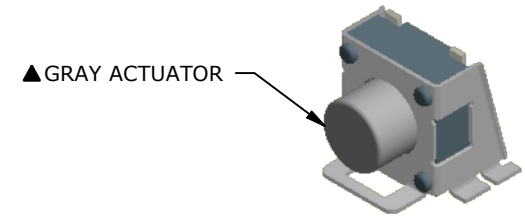

OBJECT ID
000017022

TITLE TL3360AF185Q				
SCALE 4:1	DATE 9/16/2013	DR RC	DWG N330000	REV F