

GREEN (FORWARD)

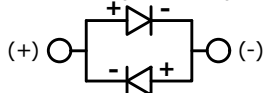

YELLOW (REVERSE)

SCHEMATIC ON-(ON)

SPDT ILLUMINATED

() DENOTES MOMENTARY FUNCTION

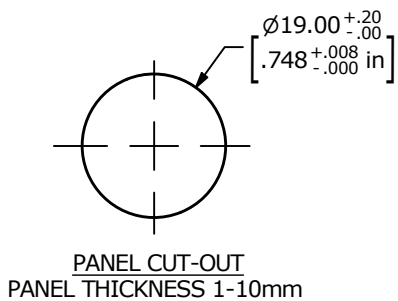

PANEL CUT-OUT
PANEL THICKNESS 1-10mm

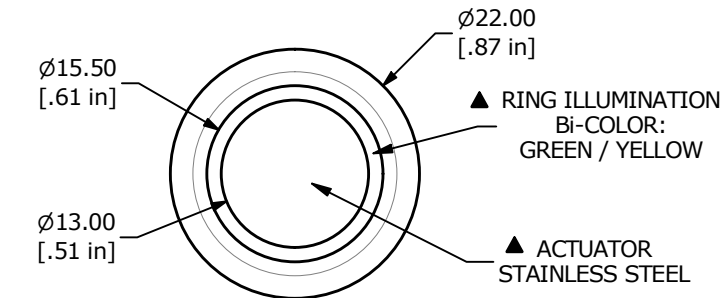

▲ RING ILLUMINATION
Bi-COLOR:
GREEN / YELLOW

▲ ACTUATOR
STAINLESS STEEL

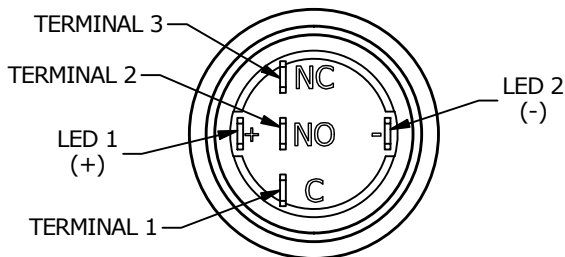
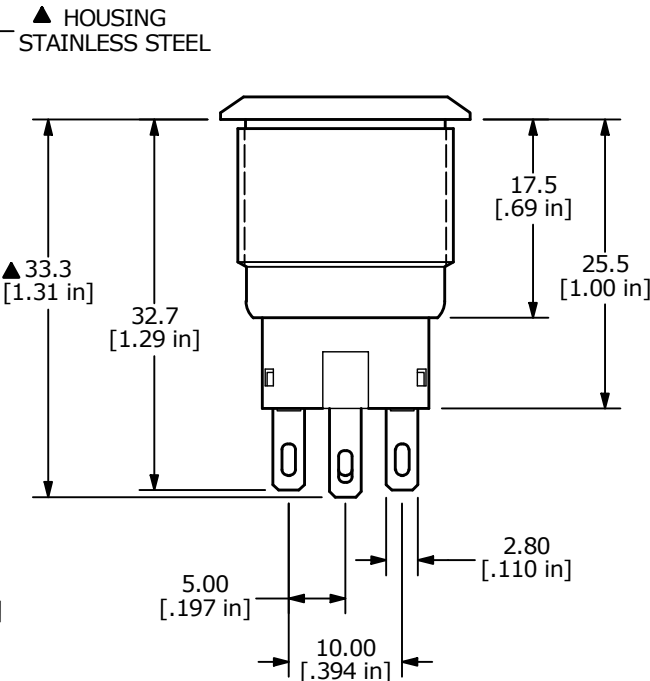
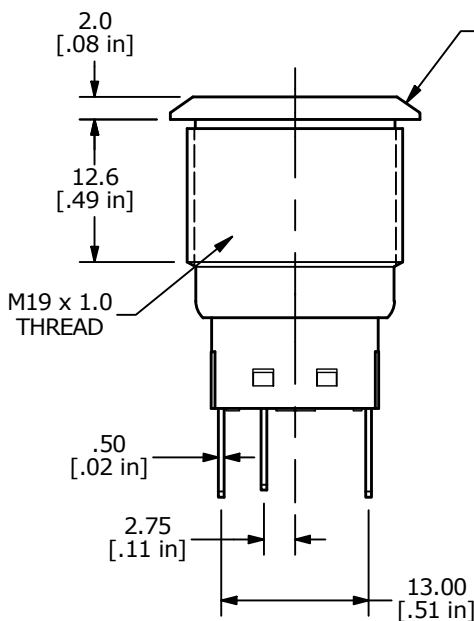
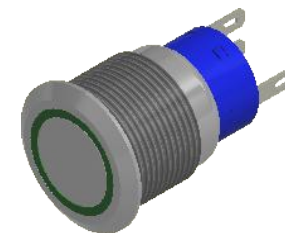

NOTE:

1. ALL DIMENSIONS IN MM [INCH]
2. GENERAL TOLERANCE: X.X = ±0.4
X.XX = ±0.25
3. TERMINAL NUMBERS FOR REF ONLY
- ▲ 4. CONTACTS and TERMINALS MATERIAL: SILVER
5. RATING: 3A 250 VAC cUL
6. ELECTRIC LIFE: 50,000 MAKE-AND-BREAK CYCLES AT FULL LOAD.
7. MECHANICAL LIFE: 1,000,000 CYCLES.
8. INSULATION RESISTANCE: 1,000 MΩ @ 500VDC MIN.
9. DIELECTRIC STRENGTH: 2,000 VAC MIN. FOR 1 MINUTE
10. CONTACT RESISTANCE: 50mΩ MAX. @ 1A 12VDC
11. OPERATING TEMP.: -20°C to 55°C
12. ▲ DENOTES CRITICAL PARAMETER.
- ▲ 13. LAMP VOLTAGE: 6V
14. TRAVEL: 20mA 3.2mm
15. ACTUATION FORCE: 2.5 ± 1.0 N
16. MOUNTING NUT TORQUE: 5-14 Nm
17. INGRESS PROTECTION: IP67, IK10
18. HARDWARE SUPPLIED: O-RING AND HEXNUT

REV	ECO NO	DESCRIPTION	DATE	BY
B	ECO-100361	UPDATE PANEL CUTOUT	12/10/21	JS



OBJECT ID
100117649

TITLE ULV4F2BSS3P3				
SCALE 3:2	DATE 7/30/2021	DR MW	DWG T940161	REV B

THE INFORMATION CONTAINED IN THIS DOCUMENT IS PROPRIETARY TO E-SWITCH AND IS NOT TO BE COPIED OR TRANSFERRED