

SWITCH	WIRE	LENGTH
SW1-1	WIRE, 24AWG AWM UL1015, YELLOW	300.0 [11.8 in]
SW1-2	WIRE, 24AWG AWM UL1015, BLUE	300.0 [11.8 in]
SW1-3	WIRE, 24AWG AWM UL1015, WHITE	300.0 [11.8 in]
SW1- (-)	WIRE, 24AWG AWM UL1015, BLACK	300.0 [11.8 in]
SW1- (+)	WIRE, 24AWG AWM UL1015, RED	300.0 [11.8 in]

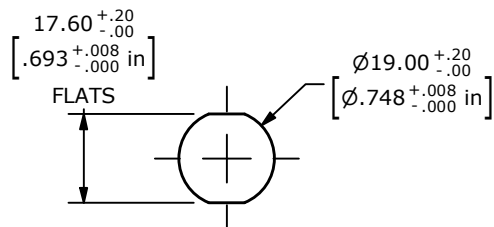
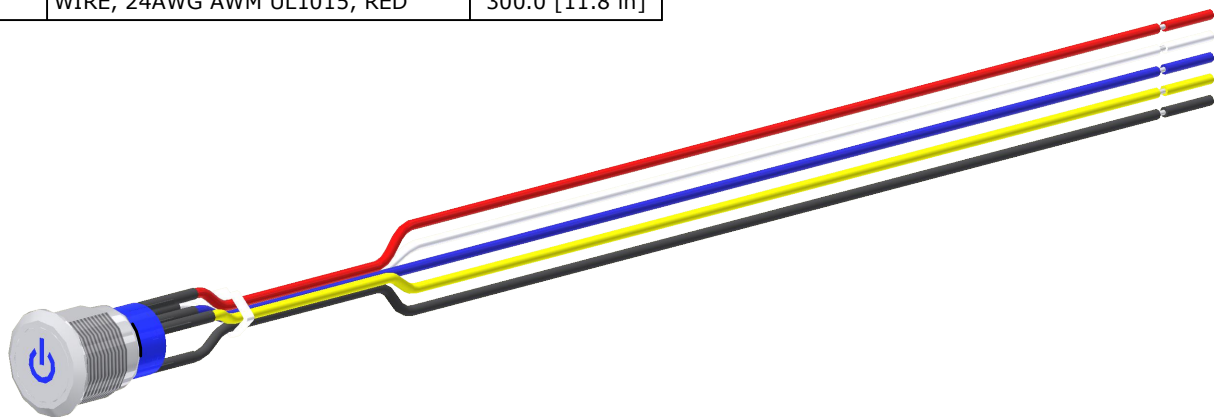

RECOMMENDED PANEL CUTOUT  
MAX. PANEL THICKNESS 10mm [.39 in]

NOTES:

1. DIMENSIONS IN MM [INCH]
2. GENERAL TOLERANCE: X.X = ±0.4  
X.XX = ±0.25
3. TERMINAL NUMBERS FOR REF ONLY
4. CONTACT MATERIAL: SILVER
5. RATING: 3A 250 VAC cUL
6. OPERATING TEMP.: -20°C to 55°C
- ▲ 7. LAMP VOLTAGE: 20mA 24V
8. TRAVEL: 3.2mm
9. ACTUATION FORCE: 2.5 ±1.0 N
10. MOUNTING NUT TORQUE: 5-14 Nm
11. INGRESS PROTECTION: IP67, IK10
12. MECHANICAL LIFE: 500,000 CYCLES.
13. ELECTRIC LIFE: 50,000 MAKE-AND-BREAK CYCLES AT FULL LOAD.
14. INSULATION RESISTANCE: 1,000 MΩ @ 500VDC MIN.
15. DIELECTRIC STRENGTH: 2,000 VAC MIN. FOR 1 MINUTE
16. CONTACT RESISTANCE: 50mΩ MAX. @ 1A 12VDC
17. ▲ DENOTES CRITICAL PARAMETER.
18. ALL MATERIAL SHALL BE ROHS COMPLIANT
- ▲ 19. SUPPLIED HARDWARE: O-RING AND HEXNUT
- ▲ 20. USE P/N'S DESIGNATED OR ENGINEERING APPROVED EQUIVALENTS

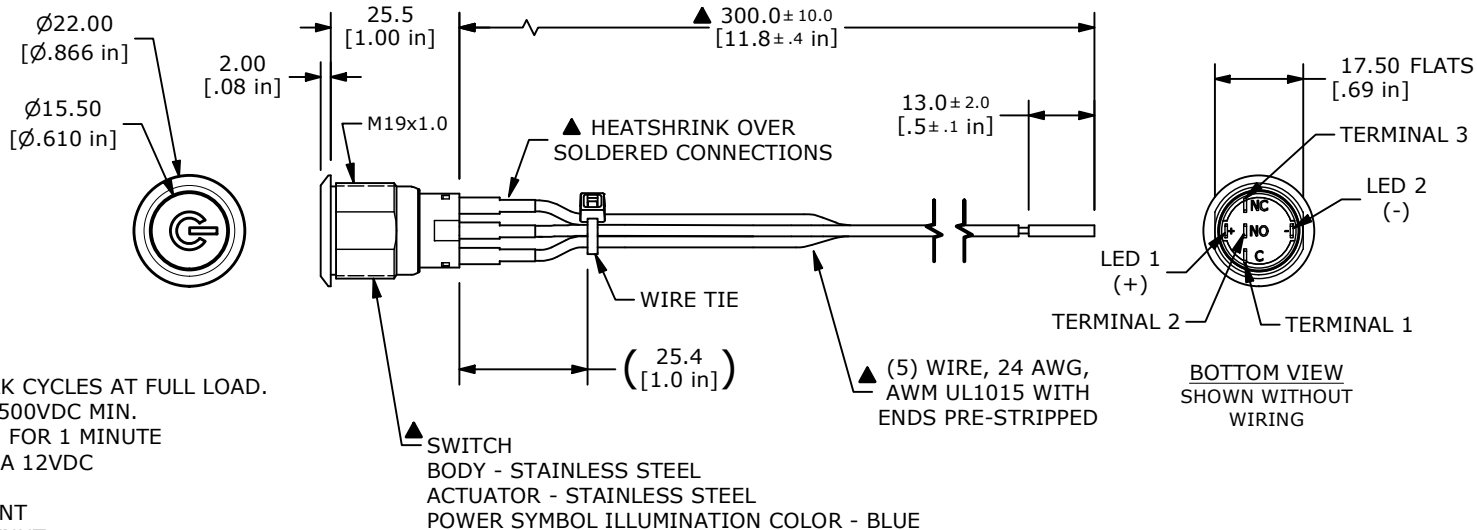

REV	ECO NO	DESCRIPTION	DATE	BY
A	ECO-102690	RELEASE	04/23/24	JS



OBJECT ID  
100127312

TITLE ULV4FW3SS545				
SCALE 2:3	DATE 4/19/2024	DR JS	DWG T940525	REV A