

SCHEMATIC
 ▲ ON - (ON)
 SPDT NON-ILLUMINATED
 (ON) = MOMENTARY FUNCTION

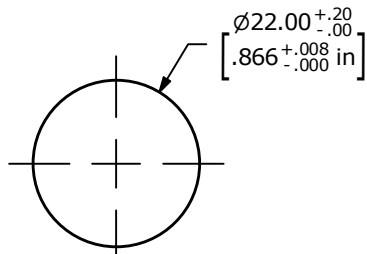

PANEL CUT-OUT
 PANEL THICKNESS 1-10mm



▲ ACTUATOR
 STAINLESS STEEL

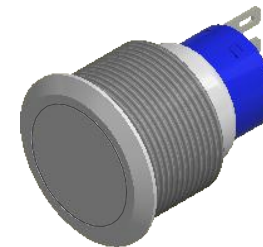

▲ HOUSING
 STAINLESS STEEL

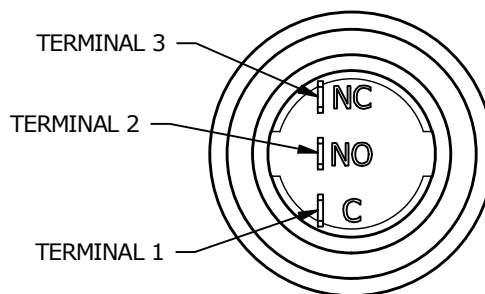
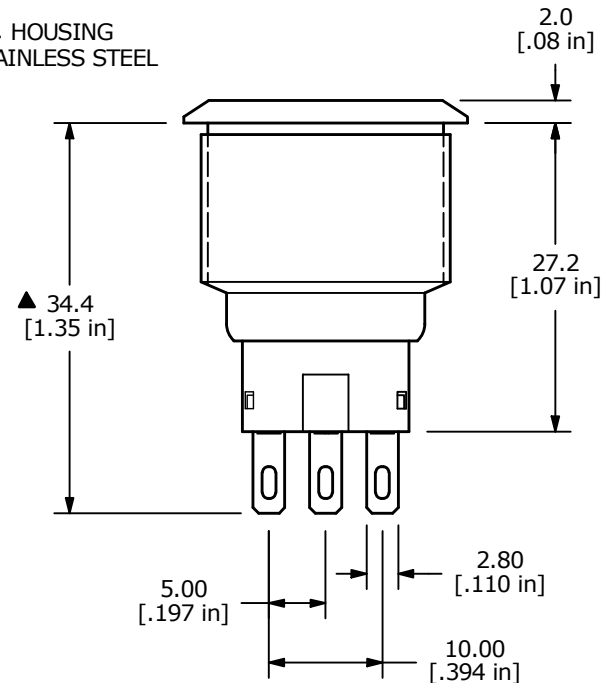
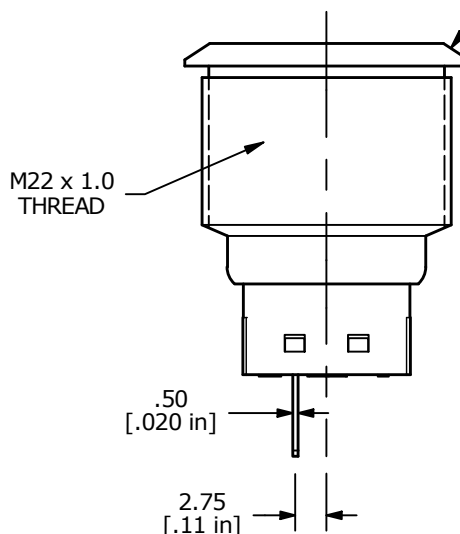

- NOTE:
1. ALL DIMENSIONS IN MM [INCH]
 2. GENERAL TOLERANCE: X.X = ±0.4
X.XX = ±0.25
 3. TERMINAL NUMBERS FOR REF ONLY
 - ▲ 4. CONTACT MATERIAL: SILVER
 5. RATING: 3A 250 VAC cUL
 6. ELECTRIC LIFE: 50,000 MAKE-AND-BREAK CYCLES AT FULL LOAD.
 7. MECHANICAL LIFE: 1,000,000 CYCLES.
 8. INSULATION RESISTANCE: 1,000 MΩ @ 500VDC MIN.
 9. DIELECTRIC STRENGTH: 2,000 VAC MIN. FOR 1 MINUTE
 10. CONTACT RESISTANCE: 50mΩ MAX. @ 1A 12VDC
 11. OPERATING TEMP.: -20°C to 55°C
 12. ▲ DENOTES CRITICAL PARAMETER.
 13. LAMP VOLTAGE: NO LAMP
 14. TRAVEL: 3.2mm
 15. ACTUATION FORCE: 2.5 ± 1.0 N
 16. MOUNTING NUT TORQUE: 5-14 Nm
 17. INGRESS PROTECTION: IP67, IK10
 18. HARDWARE SUPPLIED: O-RING AND HEXNUT

REV	ECO NO	DESCRIPTION	DATE	BY	E-SWITCH®			OBJECT ID
B	ECO-100301	UPDATE PANEL CUTOUT	09/27/21	JS	TITLE ULV7F2BSS			000026331
					SCALE 3:2	DATE 10/8/2018	DR MW	DWG T970052
								REV B

THE INFORMATION CONTAINED IN THIS DOCUMENT IS PROPRIETARY TO E-SWITCH AND IS NOT TO BE COPIED OR TRANSFERRED