

GREEN (FORWARD)

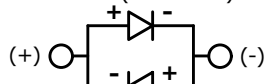

GREEN (REVERSE)

SCHMATIC
ON - (ON)
SPDT ILLUMINATED
() = MOMENTARY

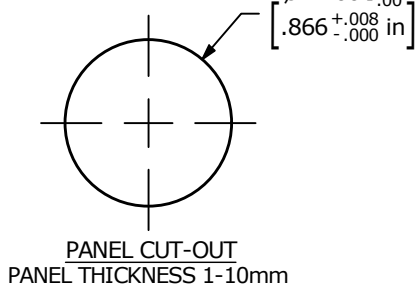

PANEL CUT-OUT
PANEL THICKNESS 1-10mm

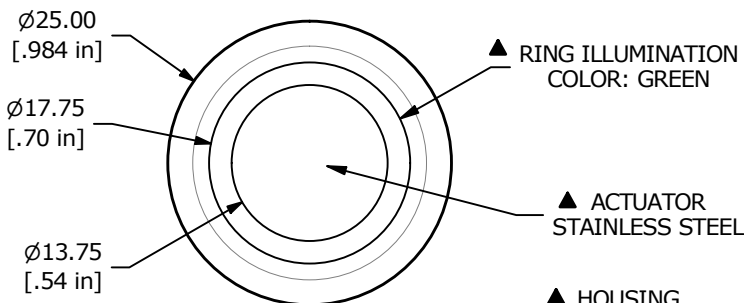

▲ RING ILLUMINATION
COLOR: GREEN

▲ ACTUATOR
STAINLESS STEEL

▲ HOUSING
STAINLESS STEEL



M22 x 1.0
THREAD

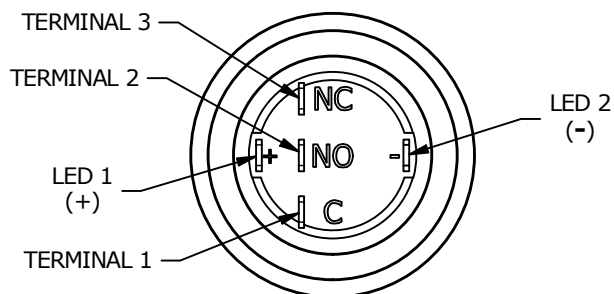
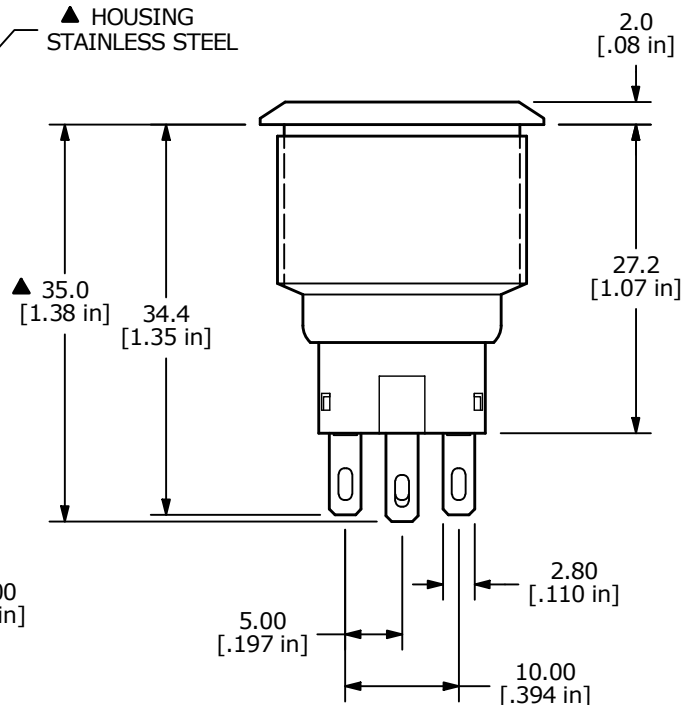
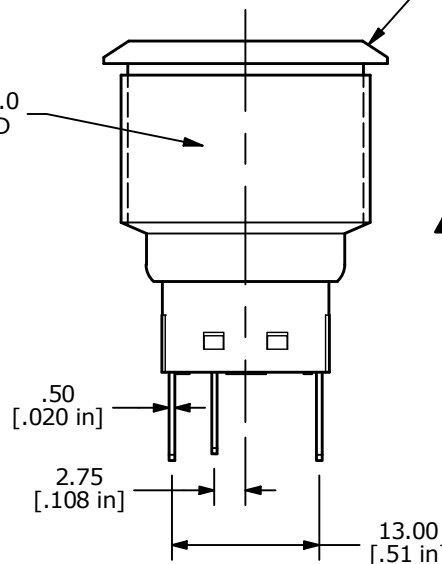

- NOTE:
1. ALL DIMENSIONS IN MM [INCH]
 2. GENERAL TOLERANCE: X.X = ±0.4
X.XX = ±0.25
 3. TERMINAL NUMBERS FOR REF ONLY
 - ▲ 4. CONTACT MATERIAL: SILVER
 5. RATING: 3A 250 VAC cUL
 6. ELECTRIC LIFE: 50,000 MAKE-AND-BREAK CYCLES AT FULL LOAD.
 7. MECHANICAL LIFE: 500,000 CYCLES.
 8. INSULATION RESISTANCE: 1,000 MΩ @ 500VDC MIN.
 9. DIELECTRIC STRENGTH: 2,000 VAC MIN. FOR 1 MINUTE
 10. CONTACT RESISTANCE: 50mΩ MAX. @ 1A 12VDC
 11. OPERATING TEMP.: -20°C to 55°C
 12. ▲ DENOTES CRITICAL PARAMETER.
 - ▲ 13. LAMP VOLTAGE: 20mA 12V
 14. TRAVEL: 3.2mm
 15. ACTUATION FORCE: 2.5 ± 1.0 N
 16. MOUNTING NUT TORQUE: 5-14 Nm
 17. INGRESS PROTECTION: IP67, IK10
 18. HARDWARE SUPPLIED: O-RING AND HEXNUT

REV	ECO NO	DESCRIPTION	DATE	BY
B	ECO-100304	UPDATE PANEL CUTOUT	09/28/21	JS



OBJECT ID
000026355

TITLE ULV7F2BSS334				
SCALE 3:2	DATE 11/13/2020	DR MW	DWG T970076	REV B