

SWITCH	WIRE	LENGTH
SW1-1	WIRE, 18 AWG AWM UL3385, YELLOW	500.0 [19.7 in]
SW1-2	WIRE, 18 AWG AWM UL3385, PURPLE	500.0 [19.7 in]
SW1-3	WIRE, 18 AWG AWM UL3385, GREEN	500.0 [19.7 in]
SW1-4	WIRE, 18 AWG AWM UL3385, YELLOW	500.0 [19.7 in]
SW1-5	WIRE, 18 AWG AWM UL3385, PURPLE	500.0 [19.7 in]
SW1-6	WIRE, 18 AWG AWM UL3385, GREEN	500.0 [19.7 in]
SW1- (-)	WIRE, 18 AWG AWM UL3385, BLACK	500.0 [19.7 in]
SW1- (+)	WIRE, 18 AWG AWM UL3385, RED	500.0 [19.7 in]

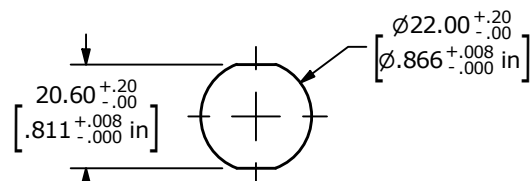
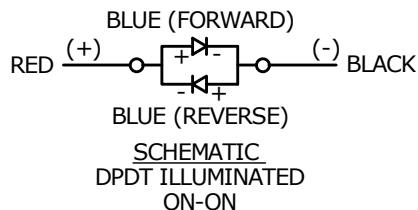
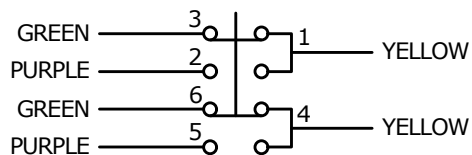

RECOMMENDED PANEL CUTOUT
MAX. PANEL THICKNESS 10mm

NOTES:

1. DIMENSIONS IN MM [INCH]
2. GENERAL TOLERANCE: X.X = ±0.4
X.XX = ±0.25
3. TERMINAL NUMBERS FOR REF ONLY
4. CONTACT MATERIAL: SILVER
5. RATING: 3A 250 VAC cUL
6. OPERATING TEMP.: -20°C to 55°C
- ▲ 7. LAMP VOLTAGE: 20mA 12V
8. TRAVEL: 3.2mm
9. ACTUATION FORCE: 5.5 ±1.0 N
10. MOUNTING NUT TORQUE: 5-14 Nm
11. INGRESS PROTECTION: IP67, IK10
12. MECHANICAL LIFE: 500,000 CYCLES.
13. ELECTRIC LIFE: 50,000 MAKE-AND-BREAK CYCLES AT FULL LOAD.
14. INSULATION RESISTANCE: 1,000 MΩ @ 500VDC MIN.
15. DIELECTRIC STRENGTH: 2,000 VAC MIN. FOR 1 MINUTE
16. CONTACT RESISTANCE: 50mΩ MAX. @ 1A 12VDC
17. ▲ DENOTES CRITICAL PARAMETER.
18. ALL MATERIAL SHALL BE ROHS COMPLIANT
- ▲ 19. SUPPLIED HARDWARE: O-RING AND HEXNUT
- ▲ 20. USE P/N's DESIGNATED OR ENGINEERING APPROVED EQUIVALENTS.

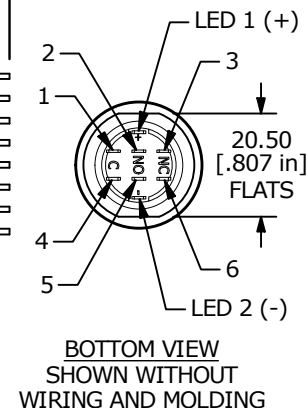
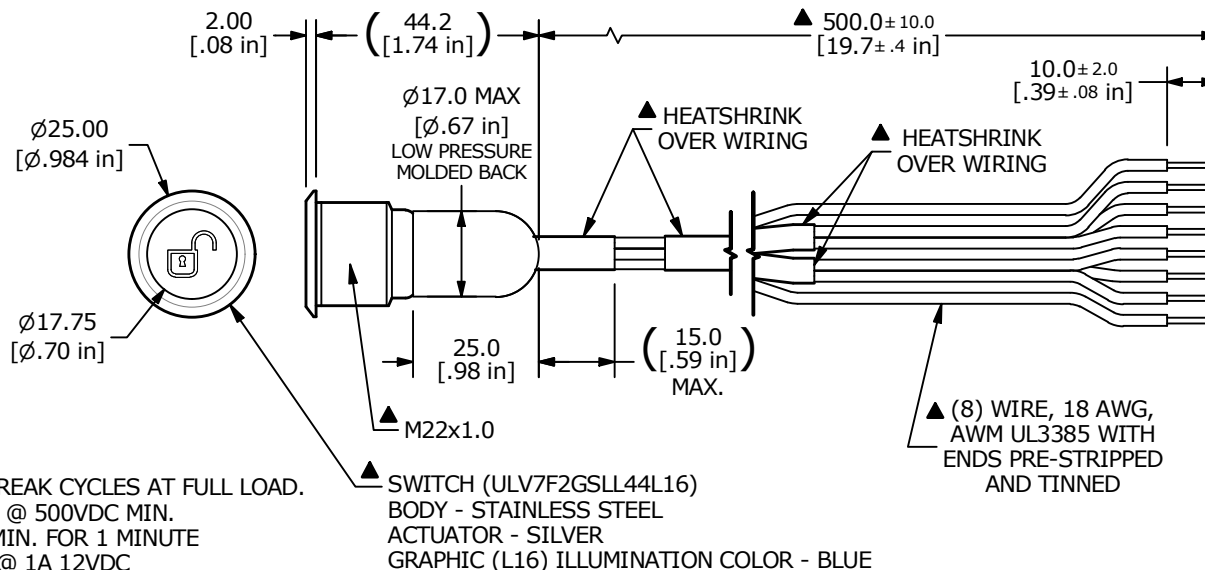
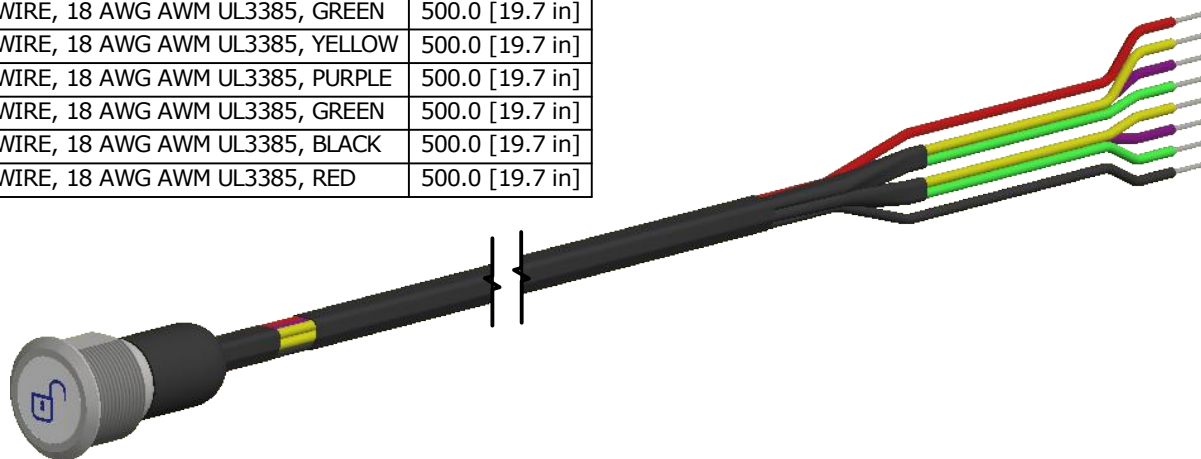

BOTTOM VIEW
SHOWN WITHOUT
WIRING AND MOLDING

REV	ECO NO	DESCRIPTION	DATE	BY
A	ECO-101998	Release	06/15/23	MW



OBJECT ID
100124891

TITLE ULV7FMGSL144L16				
SCALE 2:3	DATE 6/6/2023	DR MW	DWG T970914	REV A