

# 900 SERIES DETECTOR SWITCH

ANTI-VANDAL SWITCHES  
 DETECTOR SWITCHES  
 DIP SWITCHES  
 KEYLOCK SWITCHES  
 NAVIGATION SWITCHES  
 PUSHBUTTON SWITCHES  
 ROCKER SWITCHES  
 ROTARY SWITCHES  
 SLIDE SWITCHES  
 SNAP ACTION SWITCHES  
 TACTILE SWITCHES  
 TOGGLE SWITCHES  
 CAP OPTIONS

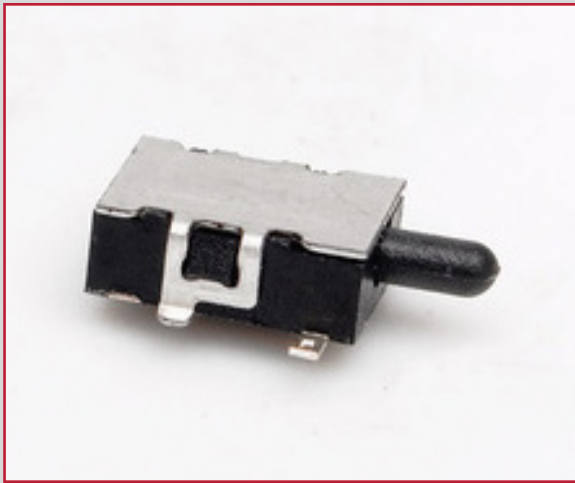

## APPLICATIONS / MARKETS

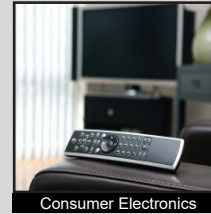
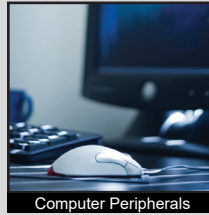

**RoHS**

## SPECIFICATIONS

**Contact Rating:** 100mA @ 50 VDC  
**Life Expectancy:** 50,000 cycles typical  
**Contact Resistance:** 80mΩ max. typical @ 2-4 VDC 100mA  
**Insulation Resistance:** 100MΩ min.  
**Dielectric Strength:** >1,000 Vrms at sea level  
**Actuation Force:** 50 gf max.  
**Operating Temperature:** -25°C to +85°C  
**Travel:** 2.0

## FEATURES & BENEFITS

- Right angle SMT detector switch
- Tape & reel packaging

## PART NUMBER CONFIGURATOR

Series



900

Mounting



A - None  
 B - Mounting Tabs

Circuit



G - Normally Open  
 H - Normally Closed

Contact Material



Q - Silver

*Specifications subject to change without notice 2.20.2023*



**E-SWITCH®**

www.e-switch.com

800.867.2717

1

# 900 SERIES DETECTOR SWITCH

## BODY DIMENSIONS

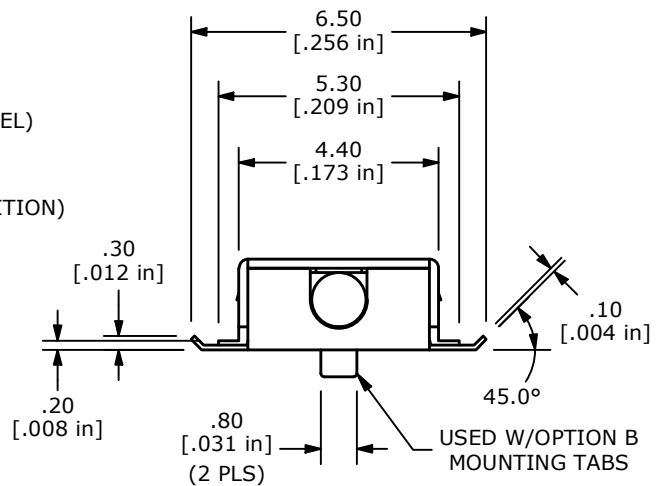
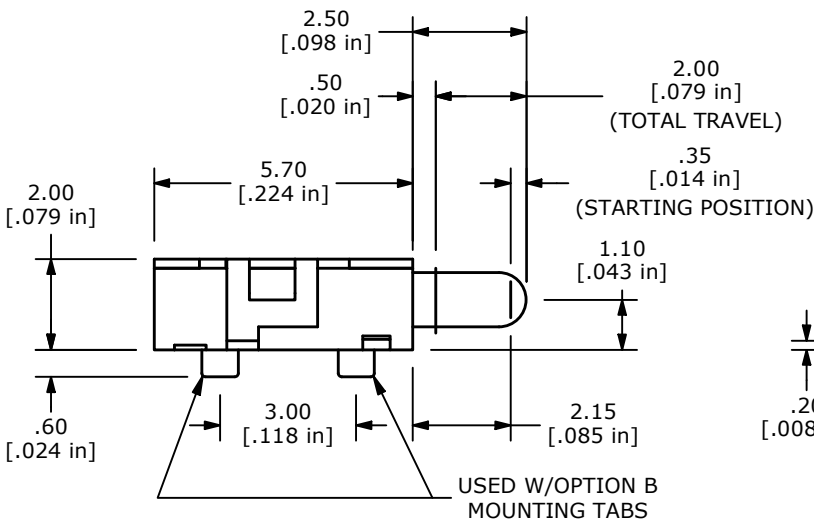
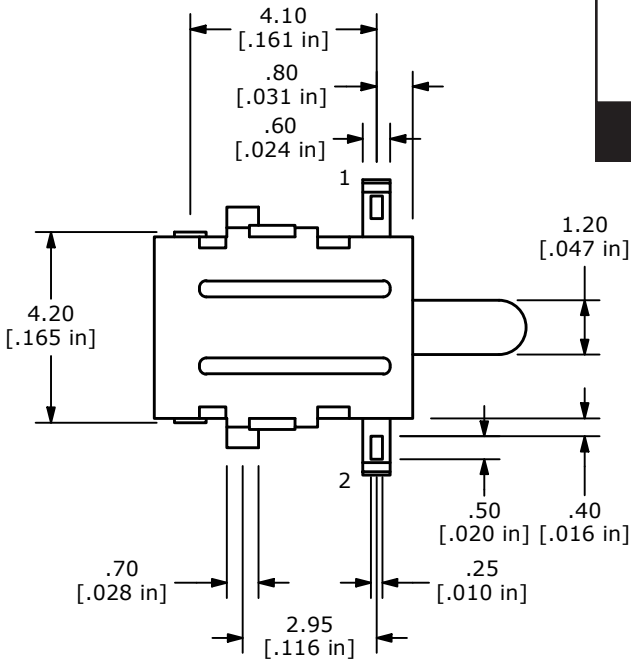
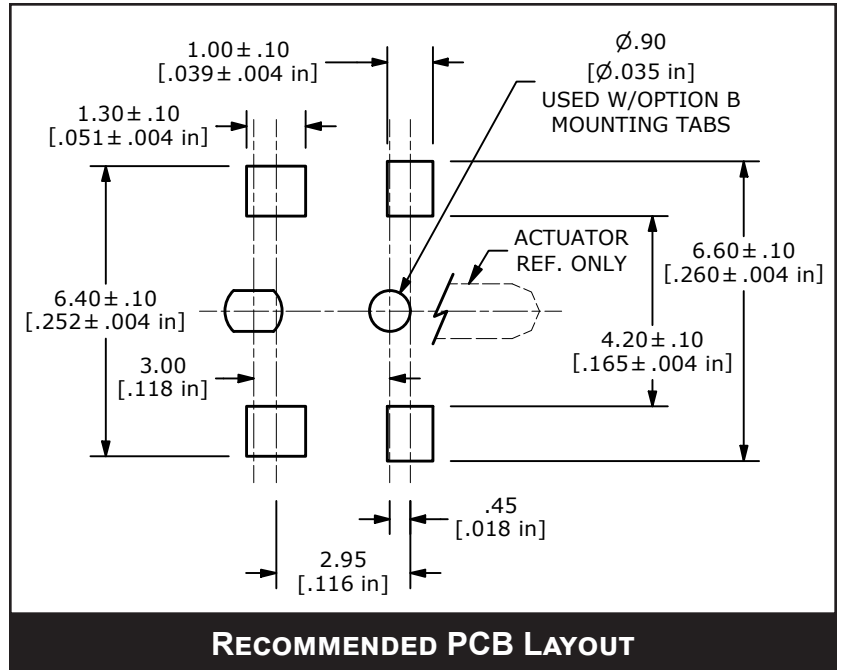
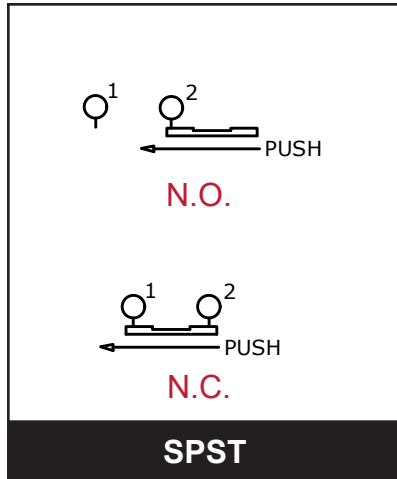

# 900 SERIES DETECTOR SWITCH

## BODY DIMENSIONS TAPE AND REEL

